

**集生产、研发、销售、服务  
于一体阀门制造企业**

Set production, research and development,  
sales and service in one valve manufacturing enterprise

**产品选型手册**  
Product selection manual

**09**

**OTHER  
VALVE SERIES  
其它阀门系列**

**QGVS**



GL41W-16C/P/R

**产品概述 Products overview**

Y型过滤器是输送介质的管道系统不可缺少的一种过滤装置, Y型过滤器通常安装在减压阀、泄压阀、定水位阀或其它设备的进口端, 用来清除介质中的杂质, 以保护阀门及设备的正常使用。Y型过滤器具有结构先进, 阻力小, 排污方便等特点。Y型过滤器适用介质可为水、油、气。一般通水网为18~30目, 通气网为10~100目, 通油网为100~480目。篮式过滤器主要由接管、主管、滤篮、法兰、法兰盖及紧固件等组成。当液体通过主管进入滤篮后, 固体杂质颗粒被阻挡在滤篮内, 而洁净的流体通过滤篮、由过滤器出口排出。

Y type filter is the medium of pipeline system is indispensable to a filtering device, Y type strainer is usually installed in a reducing valve, relief valve and the inlet water valve or other equipment, used to remove the impurity in the medium, in order to protect the valves and equipment normal use. Y type filter has the advanced structure, small resistance and easy drainage, etc. Y type filter suitable medium for water, oil and gas. Generally water network are 18 ~ 30 mu, ventilation network are 10 ~ 100 mesh, oil network 100 ~ 480 mesh. Basket strainer is mainly composed of takeover, director, filter blue, flange, flange cover, and fasteners, etc. When the liquid by supervisor into the filter can solid impurity particles will be blocked after blue within the blue filter, and clean fluid through the blue filter, the filter outlet.

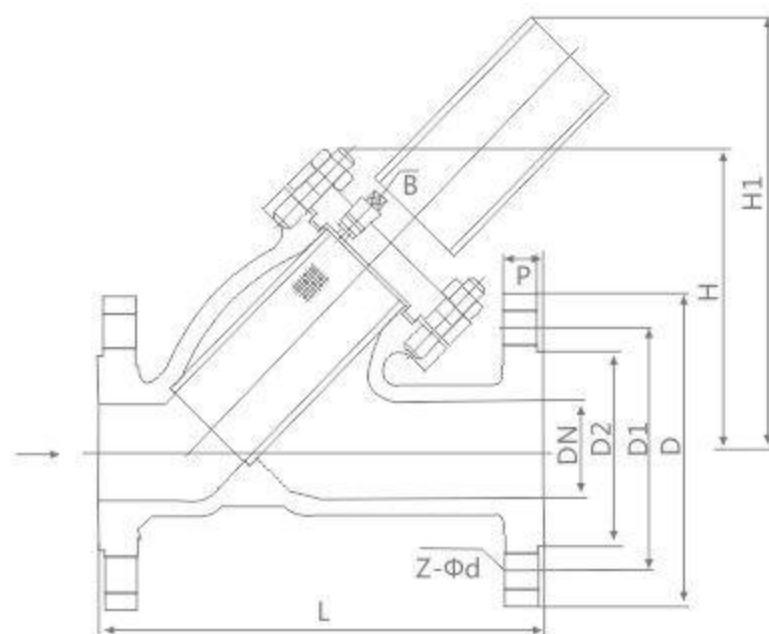

**基本参数**

介质温度: 300(°C)  
工作压差: 2KG  
材质: 不锈钢  
产品别名: Y型过滤器  
适用范围: 液体过滤  
连接形式: 法兰  
类型: 直角式  
流动方向: 单向  
适用介质: 水  
压力环境: 常压

**Basic parameters**

Medium temperature: 300(°C)  
Working pressure difference: 2 kg  
Material: stainless steel  
Product alias: Y type filter  
Scope of application: liquid filtration  
Connection: flange  
Type: the right Angle  
Flow direction: one way  
Applicable medium: water  
Pressure: the atmospheric pressure

**产品执行标准 Production enforce standard**

产品规范 Product Specification	设计规范 Design Spec	结构长度 Face to Face	连接法兰 Flange End	试验与检验 Test & Check	产品标识 Marking	供货规范 Supply
	GB/T 21637	GB/T 12221	JB/T79	JB/T 9092	GB/T 12220	JB/T 7928

**产品性能规范 Chief property and specification**

型号 Type	连接方式 Conjunction method	公称压力 PN(MPa)	耐压试验压力 (MPa)	工作压力 (MPa)	壳体材料 Material	过滤网材料 Strainer material	网总面积
SY4P-10	法兰Flange	1.0	1.1	1.0	灰铸铁 Cast ferosteel	不锈钢 Stainless steel	3~4DN
SY4P-16	法兰Flange	1.6	1.76	1.6	球墨铸铁 Ductile cast iron		
SY4P-25	法兰Flange	2.5	2.75	2.5	碳钢 Carbon steel		

**主要零件材料 Material for main parts**

零件名称 Parts Name	零部件材料 Part Material					
	25	35	1Cr18Ni9Ti	1Cr18Ni12Mo2Ti	00Cr18Ni10	00Cr17Ni14Mo2
阀体/阀盖 Body/Bonnet	25	WCB	CF8	CF8M	CF3	CF3M
网架 Dis/stem	25	35	1Cr18Ni9Ti	1Cr18Ni12Mo2Ti	00Cr18Ni10	00Cr17Ni14Mo2
滤网 Strainer	1Cr18Ni9Ti		1Cr18Ni9Ti		00Cr18Ni10	
垫片 Gasket	18-8柔性石墨 18-8/Flexible Graphite					
螺栓 Bolt	35		1Cr17Ni2		1Cr18Ni9Ti	
适用温度 Suitable temp	-29~+425°C		-40~+200°C		-40~+200°C	
适用介质 Suitable medium	水、油品、蒸汽 Water, Oil, Steam		硝酸类 Nitric Acid		醋酸类 Acetic Acid	

**主要外形和连接尺寸 Main external and connection dimension**

公称压力 PN(MPa)	公称通径 DN(mm)	尺寸(mm)						
		L	D	D1	D2	b	Z-Φd	H
1.6MPa	15	130	95	65	45	14-2	4-Φ14	60
	20	145	105	75	55	14-2	4-Φ14	70
	25	150	115	85	65	14-2	4-Φ14	70
	32	180	135	100	78	16-2	4-Φ18	75
	40	200	145	110	85	16-3	4-Φ18	90
	50	220	160	125	100	16-3	4-Φ18	105
	65	250	180	145	120	18-3	4-Φ18	150
	80	280	195	160	135	20-3	8-Φ18	175
	100	300	215	180	155	20-3	8-Φ18	200
	125	350	245	210	185	22-3	8-Φ18	205
	150	380	280	240	210	24-3	8-Φ23	260
	200	480	335	295	265	26-3	12-Φ23	300
250	550	405	355	320	30-3	12-Φ25	380	
300	610	460	410	375	30-4	12-Φ25	410	

# T TYPE FILTER T型过滤器

# BLOW-DOWN VALVE 排污阀

ST 16C/ST34C-J16~J50

### 产品概述 Products overview :

T型过滤器是除去液体中少量固体颗粒的小型设备,可保护设备的正常工作,当流体进入置有一定规格滤网的滤筒后,其杂质被阻挡,而清洁的滤液则由过滤器出口排出,当需要清洗时,只要将可拆卸的滤筒取出,处理后重新装入即可,因此,使用维护极为方便。

### 技术参数 Technical parameters :

- 1、工作温度: ≤90℃
- 2、公称口径: DN25—DN600mm
- 3、公称压力: PN≤1.6Mpa (其它工作压力可按用户要求设计)
- 4、法兰标准: GB81-59 (也可按用户要求制造)
- 5、壳体材质: A3、304、304L、316、316L
- 6、密封材料: 聚四氟乙烯、丁腈橡胶、耐油石棉胶

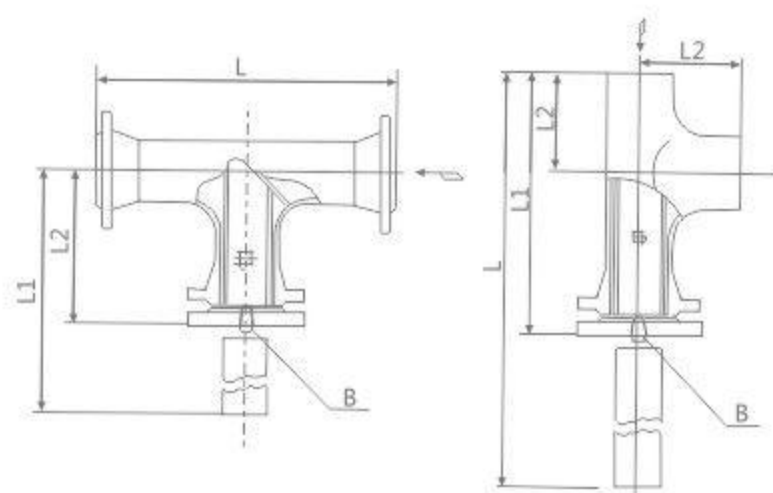

### 主要外形和连接尺寸 Main external and connection dimension

单位Unit:mm

公称口径 DN	L	L1	L2	B1排放口Blowdown Tap			有效过滤面积 Strainer Area (m <sup>2</sup> )	WT (Kg)
				I	II	III		
ST34C-J16 ST-34C-J25 ST34C-J34C ST34C-J20 ST34C-J50				R3/8"	DN20 平面 RF	DN20 凸面 M	0.00277	13.6
50	268	298	158				0.00421	18.9
65	304	337	179				0.00552	24
80	330	370	195.5				0.0088	36
100	382	432	225				0.01696	68
150	482	557	280				0.0355	140
200	578	678	332.5				0.0529	216
250	66	791	383				0.0686	315
300	768	918	437					

### 主要外形和连接尺寸 Main external and connection dimension

单位Unit:mm

公称口径 DN	L	L1	L2	B1排放口Blowdown Tap			有效过滤面积 Strainer Area (m <sup>2</sup> )	WT (Kg)
				I	II	III		
ST16C-J16 ST-16C-J25 ST16C-J40 ST16C-J20 ST16C-J50				R <sup>1</sup> / <sub>2</sub> "	DN20 平面 RF	DN20 凸面 M	0.00387	8
50	402	222	64				0.00592	12
65	469	255	76				0.00811	15
80	512	282	89				0.013	23
100	590	330	105				0.026	47
150	773	423	143				0.0459	98
200	951	510	178				0.0706	154
250	1099	599	216				0.0942	232
300	1291	691	254					

PZ44H型 PN1.6-4.0MPa

### 产品概述 Product overview

快速排污阀是由阀门演变而来的,利用齿轮旋转90度带动阀杆提升实现开启和关闭的目的。快速排污阀不仅结构简单、密封性好,而且体积小、重量轻、材料耗用少、安装尺寸小,特别是驱动力矩小,操作简便,易实现快速启闭。此外,快速排污阀可根据介质性质,使用多种材质,满足各种介质的工况要求!

### 结构特点 Structural characteristics of

- 1、阀体与阀盖采用夹箱式连接,结构紧凑,拆卸方便,便于安装,支管为焊接连接。
- 2、采用压力自紧式密封结构,密封圈由成型的石棉盘根制成,介质压力越高、密封性越好。
- 3、介质由支管流入向下排污。
- 4、阀瓣为活塞式结构,并进行渗硼处理。耐腐蚀,抗冲蚀;使用寿命长。

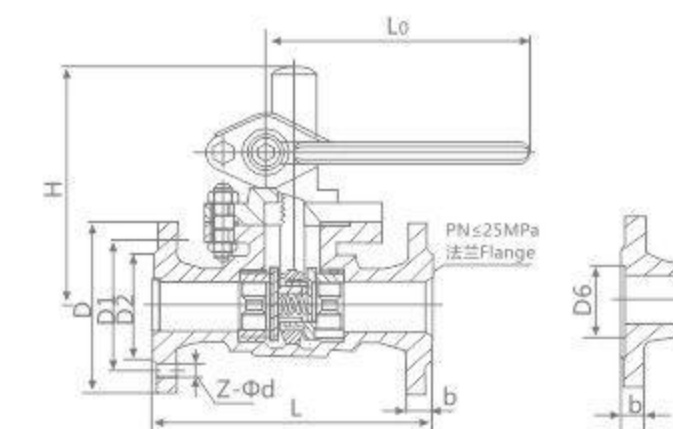

### 产品性能规范 Chief property and specification

型号 Type	公称压力PN (MPa) Nominal pressure	试验压力 (Ps/MPa) Test pressure		适用介质 Applicable medium	适用温度(°C) Applicable temperature
		强度Strength	密封Sealing		
P48H-16	16	2.4	1.8	水、蒸汽 Water, Steam	≤250
P48H-16Q					
P48H-16C					
P48H-25Q	25	3.8	2.8		≤425
P48H-25					
P48H-40	4.0	6.0	4.4		≤250
P48H-40Q					

### 主要外形和连接尺寸 Main external and connection dimension

P48H-16Q P48H-16C

公称口径 (DN/mm)	尺寸Dimension(mm)								重量 WT(kg)
	L	D	D1	D2	b	Z-Φd	H	L0	
25	160	115	85	65	14	4-Φ14	160	180	10
32	180	135	100	78	16	4-Φ18	180	200	11
40	230	145	110	85	16	4-Φ18	220	220	16
50	250	160	125	100	16	4-Φ18	230	240	20
65	265	180	145	120	18	4-Φ18	250	280	28
80	280	195	160	135	20	8-Φ18	280	350	38
100	320	215	180	155	20	8-Φ18	400	500	-

P48H-25Q P48H-25C

公称口径 (DN/mm)	尺寸Dimension(mm)								重量 WT(kg)
	L	D	D1	D2	b	Z-Φd	H	L0	
25	160	115	85	65	16	4-Φ14	160	180	10
32	180	135	100	78	18	4-Φ18	180	200	11
40	230	145	110	85	18	4-Φ18	220	220	16
50	250	160	125	100	20	4-Φ18	230	240	20
65	265	180	145	120	22	8-Φ18	250	280	28
80	280	195	160	135	22	8-Φ18	280	350	38
100	320	230	190	160	24	8-Φ23	400	500	-

P48H-40Q P48H-40C

公称口径 (DN/mm)	尺寸Dimension(mm)								重量 WT(kg)
	L	D	D1	D2	b	Z-Φd	H	L0	
25	160	115	85	65	16	4-Φ14	160	180	10
32	180	135	100	78	18	4-Φ18	180	200	11
40	230	145	110	85	18	4-Φ18	220	220	16
50	250	160	125	100	20	4-Φ18	230	240	20
65	265	180	145	120	22	8-Φ18	250	280	28
80	280	195	160	135	22	8-Φ18	280	350	38

# EXHAUST VALVE

排气阀

# FREE FLOATING BALL TYPE STEAM HYDROPHOBIC VALVE

自由浮球式蒸汽疏水阀

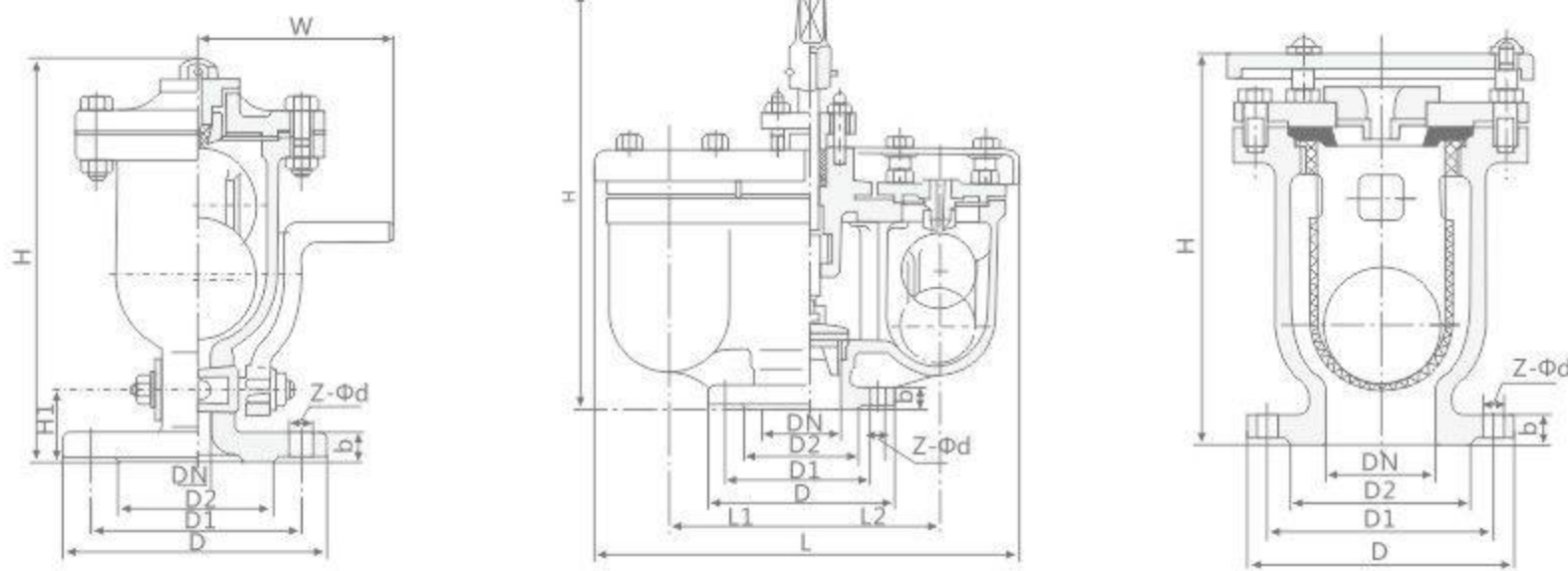

### SC11/41H-16~40C/E/D/F

#### 产品概述:

自由浮球式蒸汽疏水阀利用浮力原理,浮球根据凝结水量的多少,随水位的变化而作升降,自动调节阀座的开度,连续排放凝结水,当凝结水停止进入时,浮球降的底部,回到关闭位置,排水停止,由于排水阀座孔总是在凝结水位以下,形成水封,水、气自然分离,达到无蒸汽泄漏。

#### 产品特点:

1. 能拓饱和凝结水,回热设备内不含有水先积聚,从而获得最高的加热效率。
2. 蒸汽压力变化时,不受影响,能连续工作性能稳定
3. 漏汽变幻无常小,采用先进研磨工艺制造,浮球精度高,密封性能好。
4. 自动排空气性能好。
5. 寿命长,浮球的整个球面都可以做密封面,无集中磨损。

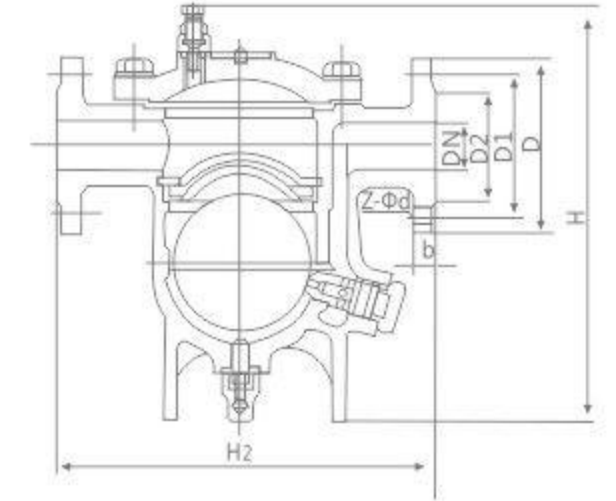

主要外形和连接尺寸 Main external and connection dimension P I -10 单位Unit:mm

公称通径 DN	主要外形和连接尺寸(mm) Main external and connecting dimensions								WT(kg)
	D	D1	D2	b	Z-Φd	H	H1	W	
PN1.0MPa									
15	211	168	125	24	4-Φ18	284	52	156	10
20	211	168	125	24	4-Φ18	303	58	156	20
25	211	168	125	24	4-Φ18	331	58	156	25

主要外形和连接尺寸 Main external and connection dimension 单位Unit:mm

公称通径 DN	主要外形和连接尺寸(mm) Main external and connecting dimensions					重量 WT(kg)
	L	G	H	H1		
CS11H-16C-C CS11H-25-C CS11H-40-C CS11H-16C-D CS11H-25-D CS11H-40-C						
15	170	1/2"	176	120		2.6
20	170	3/4"	176	120		2.8
25	170	1"	176	120		3.0
25	230	1"	215	158		5.2
32	230	1 1/4"	217	162		5.4
40	230	1 1/2"	221	166		5.6

主要外形和连接尺寸 Main external and connection dimension P II -10 单位Unit:mm

公称通径 DN	主要外形和连接尺寸(mm) Main external and connecting dimensions									WT(kg)
	L	L1	L2	D	D1	D2	b	Z-Φd	H	
PN1.0MPa										
50	472	145	145	211	168	125	24	4-Φ18	452	56
80	504	157	157	211	168	125	24	4-Φ18	459	63
100	548	173	173	238	195	152	25	4-Φ18	532	85
150	692	220	220	290	247	204	26	6-Φ18	618	145
200	692	220	220	342	299	256	27	6-Φ18	700	200

主要外形和连接尺寸 Main external and connection dimension 单位Unit:mm

公称通径 DN	主要外形和连接尺寸(mm) Main external and connecting dimensions							重量 WT(kg)
	L	D	D1	D2	b	Z-Φd	H	
CS41H-16C-C CS41H-25-C CS41H-40-C CS41H-16C-D CS41H-25-D CS41H-40-D CS41H-16C-E CS41H-25-E CS41H-40-E CS41H-16C-F CS41H-25-F CS41H-40-F								
15	195	95	65	45	14	4-Φ14	195	10.5
20	195	105	75	55	14	4-Φ14	200	11.2
25	215	115	85	65	14	4-Φ14	225	11.5
25	270	115	85	65	14	4-Φ14	245	10.5
32	270	135	100	78	16	4-Φ18	250	11.2
40	280	145	110	85	16	4-Φ18	290	11.5
40	280	145	110	85	16	4-Φ18	290	10.5
50	410	160	125	100	16	4-Φ18	380	11.2
65	410	180	145	120	18	4-Φ18	380	11.5
50	430	165	125	102	20	4-Φ18	467	72
65	430	185	145	122	20	4-Φ18	475	74
80	460	200	160	132	22	8-Φ18	492	77

主要外形和连接尺寸 Main external and connection dimension KP I II -10 JB/T82.1 单位Unit:mm

公称通径 DN	主要外形和连接尺寸(mm) Main external and connecting dimensions						WT(kg)
	D	D1	D2	b	Z-Φd	H	
PN1.0MPa							
50	160	125	100	18	4-Φ18	420	23
80	195	160	135	20	4-Φ18	500	37
100	215	180	155	22	8-Φ18	549	48
150	280	240	210	24	8-Φ23	615	67
200	335	295	265	24	8-Φ23	729	120
50	211	168	125	24	4-Φ18	420	25
80	211	168	124	24	4-Φ18	500	39
100	238	195	152	25	4-Φ18	549	50
150	390	247	204	26	6-Φ18	615	69
200	342	299	256	27	6-Φ18	729	125

# GB X43W STAINLESS STEEL PLUG VALVE

国标X43W不锈钢旋塞阀

# GB X44W STAINLESS STEEL PLUG VALVE

国标X44W不锈钢旋塞阀

X43W旋塞阀

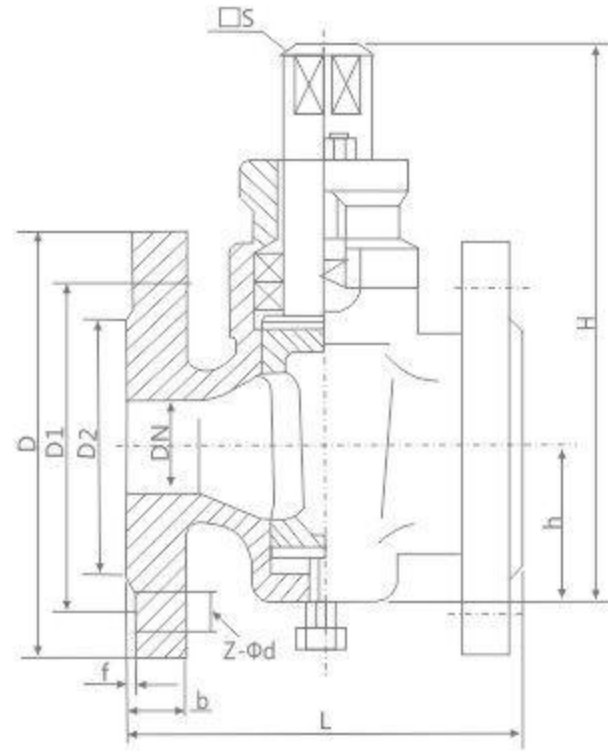

产品规范 Product specification

型号	公称压力 PN (MPa)	试验压力 PS (MPa)		适用介质	工作温度 (°C)
		壳体	密封		
X43W-10P	1.0	1.5	1.1	煤气、油品	≤200
		1.5	1.1		

主要外形和连接尺寸 Main external and connection dimension

JB/T82.1

公称压力 PN(MPa)	公称口径 DN(mm)	主要外形和连接尺寸 Main External and Connection Dimension									
		L	D	D1	D2	f	b	Z-φd	□s	h	H
1.0	15	80	95	65	45	2	12	4-φ14	14	26	99
	20	90	105	75	55	2	14	4-φ14	14	34	124
	25	110	115	85	65	2	14	4-φ14	17	38	133
	32	130	135	100	78	2	16	4-φ18	18	45	152
	40	150	145	110	85	3	18	4-φ18	26	55	212
	50	170	160	125	100	3	18	4-φ18	28	74	260
	65	220	180	145	120	3	20	4-φ18	32	82	295
	80	250	195	160	135	3	20	4-φ18	40	95	327
	100	300	215	180	155	3	22	8-φ18	45	135	825
	125	350	245	210	185	3	24	8-φ18	54	154	482
	150	400	280	240	210	3	24	8-φ23	62	172	512
	200	460	335	295	265	3	24	8-φ23	75	195	605
	250	530	390	350	320	3	26	12-φ23	85	230	660
	300	580	440	400	368	4	28	12-φ23	100	263	760

二通旋塞阀概述 Two-way plug valve overview

X44W-10C三通法兰式旋塞阀适用范围城建、化工、冶金、石油、制药、食品、饮料、环保  
产品特点：X44W-10PR、X44W-10C三通法兰式旋塞阀，三通法兰式旋塞阀

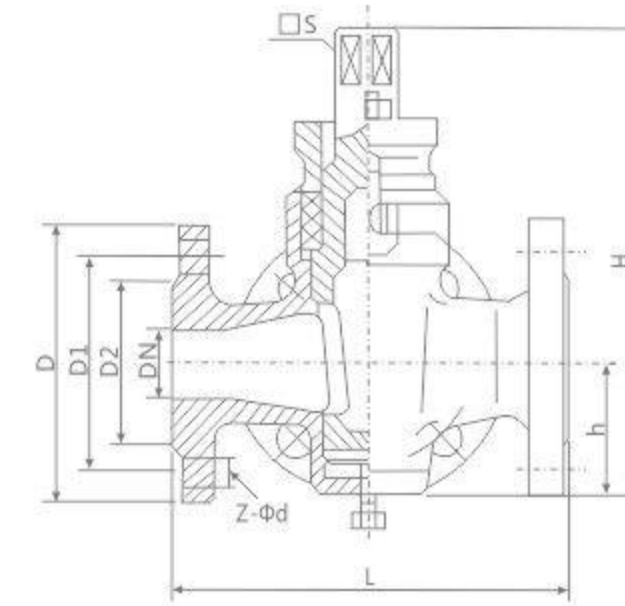

产品规范 Product specification

型号	公称压力 PN(MPa)	试验压力 PS(MPa)		适用介质	工作温度 (°C)
		壳体	密封		
X44W-10P	1.0	1.5	1.1	硝酸类	≤250
X44W-10R	1.0	1.5	1.1	醋酸类	≤250
X44W-10C	1.0	1.5	1.1	煤气、油品	≤200

主要外形尺寸和连接尺寸 Main external and connection dimension

JB/T82.1

公称压力 PN(MPa)	公称口径 DN(mm)	主要外形尺寸和连接尺寸 Main External and Connection Dimension									
		L	D	D1	D2	Z-φd	□s	h	H		
1.0	15	145	95	65	45	4-φ14	14	26	99		
	20	145	105	75	55	4-φ14	14	34	124		
	25	145	115	85	65	4-φ14	17	38	133		
	32	165	135	100	78	4-φ18	19	45	152		
	40	190	145	110	85	4-φ18	22	55	212		
	50	200	160	125	100	4-φ18	27	74	260		
	65	230	180	145	120	4-φ18	32	82	295		
	80	260	195	160	135	4-φ18	36	95	327		
	100	300	215	180	155	8-φ18	46	135	425		
	125	350	245	210	185	8-φ18	50	154	482		
	150	400	280	240	210	8-φ23	55	172	512		
	200	480	335	295	265	8-φ23	75	195	605		
	250	530	390	350	320	12-φ23	85	230	660		
	300	610	440	400	368	12-φ23	100	263	760		

**FLANGE  
PARAMETER TABLE**  
法兰参数对照表

**FLANGE  
PARAMETER TABLE**  
法兰参数对照表

表1 PN0.6MPa (6压力) 板式平焊钢制管法兰 mm

公称 口径 DN	管子外径 A1		连接尺寸					密封面尺寸		法兰 厚度 C	法兰内径 B1		坡口 宽度 b	法兰理论 重量系列 Z kg
			法兰外径 系列1/系列2 D	螺栓孔 中心圆 直径K	螺栓孔直径 系列1/系列2 L	螺栓、螺柱								
	数量n	螺纹Th. 系列1/系列2				d	f							
10	17.2	14	75	50	12	4	M10	32	2	12	18	15	3	0.32
15	21.3	18	80	55	12	4	M10	40	2	12	22	19	3	0.34
20	26.9	25	90	65	12	4	M10	50	2	14	27.5	26	3	0.54
25	33.7	32	100	75	12	4	M10	60	2	14	34.5	33	4	0.64
32	42.4	38	120	90	14	4	M12	70	2	16	43.5	39	4	1.10
40	48.3	45	130	100	14	4	M12	80	3	16	49.5	46	4	1.22
50	60.3	57	140	110	14	4	M12	90	3	16	61.5	59	4	1.35
65	76.1	76	160	130	14	4	M12	110	3	16	77.5	78	5	1.67
80	88.9	89	190/185	150	18	4	M16	125	3	18	90.5	91	5	2.48
100	114.3	108	210/205	170	18	4	M16	145	3	18	116	110	5	2.89
125	139.7	133	240/235	200	18	8	M16	175	3	20	141.5	135	5	3.94
150	168.3	159	265/260	225	18	8	M16	200	3	20	170.5	161	5	4.47
175		194	290	255	18	8	M16	230	3	22		196	6	5.54
200	219.1	219	320/315	280	18	8	M16	255	3	22	221.5	222	7	6.07
225		245	340	305	18	8	M16	280	3	22		248	8	6.60
250	273	273	375/370	335	18	12	M16	310	3	24	276.5	276	9	8.03
300	323.9	325	440/435	395	23	12	M20	362	4	24	327.5	328	9	10.30
350	355.6	377	490/485	445	23	12	M20	415	4	26	359.5	380	10	12.59
400	406.4	426	540/535	495	23	16	M20	462	4	28	411	430	10	15.20
450	457	480	595/590	550	23	16	M20	518	4	28	462	484	10	17.59
500	508	530	645/640	600	23	20/16	M20	568	4	30	513.5	534	10	20.67注意
600	610	630	755	705	26/25	20	M24/M22	670	5	30	616.5	634	10	26.57
700	711	720	860	810	26/25	24	M24/M22	755	5	32	715	724	10	37.10
800	813	820	975	920	30	24	M27	880	5	32	817	824	10	46.20
900	914	920	1075	1020	30	24	M27	980	5	34	918	924	10	55.10
1000	1016	1020	1175	1120	30	28	M27	1080	5	36	1020	1024	10	64.36
1200	1219	1220	1405/1400	1340	34	32	M30	1295	5	30	1223	1224	12	73参考
1300		1320	1520	1450	34	32	M30	1405	5	30		1324	12	80参考
1400	1422	1420	1630/1620	1560	36/34	36	M33/M30	1510	5	34	1426	1424	14	105参考
1500		1520	1720	1660	34	36	M30	1610	5	34		1524	14	115参考
1600	1626	1620	1830/1820	1760	36/34	40	M33/M30	1710	5	36	1630	1624	16	125参考
1750			1995	1920	41	44	M36	1860	5	36			16	155参考
1800	1829	1820	2045	1970	41	44	M36	1910	5	38	1833	1824	17	170参考
2000	2032	2020	2265	2180	42/48	48	M39/M42	2110	5	38	2036	2024	19	210参考
2200			2475	2390	48	52	M42	2330	6	40			20	240参考
2400			2685	2600	48	56	M42	2540	6	42			22	300参考

表2 PN1.0MPa (10压力) 板式平焊钢制管法兰 mm

公称 口径 DN	管子外径 A1		连接尺寸					密封面尺寸		法兰 厚度 C	法兰内径 B1		坡口 宽度 b	法兰理论 重量系列 Z kg
			法兰外径 系列1/系列2 D	螺栓孔 中心圆 直径K	螺栓孔直径 系列1/系列2 L	螺栓、螺柱								
	数量n	螺纹Th. 系列1/系列2				d	f							
10	17.2	14	90	60	14	4	M12	40	2	12	18	15	3	0.46
15	21.3	18	95	65	14	4	M12	45	2	12	22	19	3	0.51
20	26.9	25	105	75	14	4	M12	55	2	14	27.5	26	3	0.75
25	33.7	32	115	85	14	4	M12	65	2	14	34.5	33	4	0.89
32	42.4	38	140/135	100	18	4	M16	78	2	16	43.5	39	4	1.40
40	48.3	45	150/145	110	18	4	M16	85	3	18	49.5	46	4	1.71
50	60.3	57	165/160	125	18	4	M16	100	3	18	61.5	59	4	2.09
65	76.1	76	185/180	145	18	4	M16	120	3	20	77.5	78	5	2.84
80	88.9	89	200/195	160	18	3/4	M16	135	3	20	90.5	91	5	3.24注意
100	114.3	108	220/215	180	18	8	M16	155	3	22	116	110	5	4.01
125	139.7	133	250/245	210	18	8	M16	185	3	24	141.5	135	5	5.46
150	168.3	159	285/280	240	23	8	M20	210	3	24	170.5	161	5	6.67
175		194	310	270	23	8	M20	240	3	24		196	6	7.44
200	219.1	219	340/335	295	23	8	M20	265	3	24	221.5	222	7	8.24
225		245	365	325	23	8	M20	295	3	24		248	8	9.30
250	273	273	395/390	350	23	12	M20	320	3	26	276.5	276	9	10.7
300	323.9	325	445/440	400	23	12	M20	363	4	28	327.5	328	9	12.9
350	355.6	377	505/500	460	23	16	M20	423	4	28	359.5	380	10	15.9
400	406.4	426	565	515	26/25	16	M24/M22	482	4	30	411	430	10	21.8
450	457	480	615	565	26/25	20	M24/M22	532	4	30	462	484	10	24.4
500	508	530	670	620	26/25	20	M24/M22	585	4	32	513.5	534	10	27.7
600	610	630	780	725	30	20	M27	685	5	36	616.5	634	10	39.4
700	711	720	895	840	30	24	M27	800	5	36	715	724	10	53
800	813	820	1015/1010	950	34	24	M30	905	5	38	817	824	10	67
900	914	920	1115/1110	1050	34	28	M30	1005	5	38	918	924	10	76参考
1000	1016	1020	1230/1220	1160	36/34	28	M33/M30	1115	5	38	1020	1024	10	90参考
1200	1219	1220	1340	1270	36	28	M33	1222	5	40		1124	10	125参考
1300		1320	1455/1450	1380	39/41	32	M36	1325	5	44	1223	1224	12	143参考
1400	1422	1420	1575	1490	41	32	M36	1420	5	46		1324	12	180参考
1500		1520	1575	1590	42/48	36	M39/M42	1525	5	48	1426	1424	14	195参考
1600	1626	1620	1785	1700	48	36	M42	1640	5	50		1524	14	225参考
1750			1915	1820	48/54	40	M45/M48	1750	5	52	1630	1624	16	275参考
1800	1829	1820	2065	1970	54	44	M48	1900	5	54			16	310参考
2000	2032	2020	2115	2020	48/54	44	M45/M48	1950	5	56	1833	1824	17	340参考
2200			2325	2230	48/54	48	M45/M48	2160	5	60	2036	2024	18	420参考
2400			2550	2440	56	52	M52	2370	6	80			20	660参考

**FLANGE  
PARAMETER TABLE**  
法兰参数对照表

**FLANGE  
PARAMETER TABLE**  
法兰参数对照表

表3 PN1.6MPa (16压力) 板式平焊钢制管法兰 mm

公称 口径 DN	管子外径 A1		连接尺寸					密封面尺寸		法兰 厚度 C	法兰内径 B1		坡口 宽度 b	法兰理论 重量系列 Z kg
			法兰外径 系列1/系列2 D	螺栓孔 中心圆 直径K	螺栓孔直径 系列1/系列2 L	螺栓、螺柱								
	数量n	螺纹Th. 系列1/系列2				d	f							
10	17.2	14	90	60	14	4	M12	40	2	14	18	15	3	0.55
15	21.3	18	95	65	14	4	M12	45	2	14	22	19	3	0.71
20	26.9	25	105	75	14	4	M12	55	2	16	27.5	26	3	0.87
25	33.7	32	115	85	14	4	M12	65	2	18	34.5	33	4	1.18
32	42.4	38	140/135	100	18	4	M16	78	2	18	43.5	39	4	1.60
40	48.3	45	150/145	110	18	4	M16	85	3	20	49.5	46	4	2.00
50	60.3	57	165/160	125	18	4	M16	100	3	22	61.5	59	4	2.61
65	76.1	76	185/180	145	18	4	M16	120	3	24	77.5	78	5	3.45
80	88.9	89	200/195	160	18	8	M16	135	3	24	90.5	91	5	3.71
100	114.3	108	220/215	180	18	8	M16	155	3	24	116	110	5	4.80
125	139.7	133	250/245	210	18	8	M16	185	3	28	141.5	135	5	6.47
150	168.3	159	285/280	240	23	8	M20	210	3	28	170.5	161	5	7.92
175		194	310	270	23	8	M20	240	3	28		196	6	8.81
200	219.1	219	340/335	295	23	12	M20	265	3	30	221.5	222	7	10.10
225		245	365	325	23	12	M20	295	3	30		248	8	11.20
250	273	273	405	355	26/25	12	M24/M22	320	3	32	276.5	276	9	15.70
300	323.9	325	460	410	26/25	12	M24/M22	375	4	32	327.5	328	9	18.10
350	355.6	377	520	470	26/25	16	M24/M22	436	4	34	359.5	380	10	23.30
400	406.4	426	580	525	30	16	M27	485	4	38	411	430	10	31.00
450	457	480	640	585	30	20	M27	515	4	42	462	484	10	40.20
500	508	530	715/705	650	34	20	M30	608	4	48	513.5	534	10	55.20
600	610	630	840	770	36/41	20	M33/M36	718	5	50	616.5	634	10	80.80
700	711	720	910	840	36/41	24	M33/M36	788	5	50	715	724	10	106.0
800	813	820	1025/1020	950	39/41	24	M36	898	5	52	817	824	10	130.5
900	914	920	1125/1120	1050	39/41	28	M36	998	5	44	918	924	10	91参考
1000	1016	1020	1255	1170	42/48	28	M39/M42	1110	5	46	1020	1024	10	127参考
1100		1120	1370	1280	42	28	M39	1222	5	50		1124	10	160参考
1200	1219	1220	1485	1390	48/54	32	M45/M48	1325	5	52	1223	1224	12	186参考
1300		1320	1585	1490	54	32	M48	1425	5	54		1324	12	215参考
1400	1422	1420	1685	1590	48/54	36	M48/M45	1525	5	58	1426	1424	14	245参考
1500		1520	1820	1710	54	36	M48	1640	5	60		1524	14	320参考
1600	1626	1620	1930	1820	55/58	40	M52	1750	5	64	1630	1624	16	360参考
1750			2080	1970	58	44	M52	1900	5	66			16	400参考
1800	1829	1820	2130	2020	55/58	44	M52	1950	5	68	1833	1824	17	430参考
2000	2032	2020	2345	2230	60	48	M56	2150	5	70	2036	2024	18	515参考

※系列1国家标准GB/T9119-2000/系列2机械行业标准JB/T81-94

表4 PN2.5MPa (25压力) 板式平焊钢制管法兰 mm

公称 口径 DN	管子外径 A1		连接尺寸					密封面尺寸		法兰 厚度 C	法兰内径 B1		坡口 宽度 b	法兰理论 重量系列 Z kg
			法兰外径 系列1/系列2 D	螺栓孔 中心圆 直径K	螺栓孔直径 系列1/系列2 L	螺栓、螺柱								
	数量n	螺纹Th. 系列1/系列2				d	f							
10	17.2	14	90	60	14	4	M12	40	2	16	18	15	3	0.64
15	21.3	18	95	65	14	4	M12	45	2	16	22	19	3	0.80
20	26.9	25	105	75	14	4	M12	55	2	18	27.5	26	3	0.99
25	33.7	32	115	85	14	4	M12	65	2	18	34.5	33	4	1.18
32	42.4	38	140/135	100	18	4	M16	78	2	20	43.5	39	4	1.96
40	48.3	45	150/145	110	18	4	M16	85	3	22	49.5	46	4	2.60
50	60.3	57	165/160	125	18	4	M16	100	3	24	61.5	59	4	2.71
65	76.1	76	185/180	145	18	8	M16	120	3	24	77.5	78	5	3.22
80	88.9	89	200/195	160	18	8	M16	135	3	26	90.5	91	5	4.06
100	114.3	108	235/230	190	23	8	M20	160	3	28	116	110	5	6.00
125	139.7	133	270	220	26/25	8	M24/M22	188	3	30	141.5	135	5	8.26
150	168.3	159	300	250	26/25	8	M24/M22	218	3	30	170.5	161	5	10.40
175		194	330	280	26/25	12	M24/M22	248	3	32		196	6	11.90
200	219.1	219	360	310	26/25	12	M24/M22	278	3	32	221.5	222	7	14.50
225		245	395	340	30	12	M27	302	3	34		248	8	17.00
250	273	273	425	370	30	12	M27	332	3	34	276.5	276	9	18.90
300	323.9	325	485	430	30	16	M27	390	4	36	327.5	328	9	26.80
350	355.6	377	555/550	490	34	16	M30	448	4	42	359.5	380	10	34.35
400	406.4	426	620/610	550	36/34	16	M33/M30	505	4	44	411	430	10	44.90
450	457	480	670/660	600	36/34	20	M33/M30	555	4	48	462	484	10	51.92
500	508	530	730	660	36/41	20	M33/M36	610	4	52	513.5	534	10	67.30
600	610	630	845/840	770	41	20	M36	718	5	56	616.5	634	10	95.20
700	711	720	960/955	875	42/48	24	M39/M42	815	5	60	715	724	10	116
800	813	820	1085/1070	990	48	24	M45/M42	930	5	64	817	824	10	150.2
900	914	920	1185/1180	1090	48/54	28	M45/M48	1025	5	58	918	924	10	160参考
1000	1016	1020	1320/1305	1210	55/58	28	M52	1140	5	62	1020	1024	10	210参考
1100		1124	1425	1315	55	28	M52	1245	5	66		1124	10	260参考
1200	1219	1220	1530/1525	1420	55/58	32	M52	1350	5	70	1223	1224	12	300参考
1300		1320	1640	1530	65	32	M56	1450	5	74		1324	12	355参考
1400	1422	1420	1755/1750	1640	60/65	36	M56	1560	5	76	1426	1424	14	450参考
1500		1520	1865	1750	60	36	M56	1670	5	80		1524	14	530参考
1600	1626	1620	1975	1860	60	40	M56	1780	5	84	1630	1624	16	570参考
1800	1829	1820	2195	2070	68	44	M64	1985	5	90	1833	1824	17	700参考
2000	2032	2020	2425	2300	68	48	M64	2210	5	96	2036	2024	18	900参考

※系列1国家标准GB/T9119-2000/系列2机械行业标准JB/T81-94

**FLANGE  
PARAMETER TABLE**  
法兰参数对照表

**FLANGE  
PARAMETER TABLE**  
法兰参数对照表

表5 PN4.0MPa (40压力) 凹凸面对焊钢制管法兰 mm

公称 口径 DN	管子外径 A1		连接尺寸					密封面尺寸					法兰颈					法兰理论 重量系列 2 kg			
	国际 A管	国内 B管	法兰外径 系列1/ 系列2 D	螺栓 孔中 心直 径 K	螺栓孔 直径 系列1/ 系列2 L	螺栓、螺柱		d	X凸面 系列1/ 系列2	Y凹面 系列1/ 系列2	f	f1 f2	法兰 厚度 C	法兰 内径 B	法兰 高度 H	颈部 直径 Nmax	法兰 壁厚 S	直边 段 H1	圆角 半径 R	A型	B型
						数量 n	螺纹Th. 系列1/ 系列2														
10	17.2	14	90	60	14	4	M12	40	34	35	2	4	16	8	35	26	2.3	6	3	0.77	0.67
15	21.3	18	95	65	14	4	M12	45	39	40	2	4	16	12	35	30	3.2	6	3	0.87	0.77
20	26.9	25	105	75	14	4	M12	55	50	51	2	4	16	18	36	38	3.2	6	4	1.09	0.97
25	33.7	32	115	85	14	4	M12	65	57	58	2	4	16	25	38	45	3.2	6	4	1.31	1.18
32	42.4	38	140/135	100	18	4	M16	78	65	66	2	4	18	31	45	56	3.6	6	5	2.17	1.98
40	48.3	45	150/145	110	18	4	M16	85	75	76	3	4	18	38	48	64	3.6	7	5	2.51	2.14
50	60.3	57	165/160	125	18	4	M16	100	87	88	3	4	20	48	48	76	4	8	5	3.34	2.92
65	76.1	76	185/180	145	18	4	M16	120	109	110	3	4	22	66	52	96	5	10	6	4.34	3.85
80	88.9	89	200/195	160	18	8	M16	135	120	121	3	4	24	78	58	112	5.6	12	6	5.52	5.03
100	114.3	108	235/230	190	23	8	M20	160	149	150	3	4.5	26	96	68	138	6.3	12	6	8.39	7.71
125	139.7	133	270	220	26/25	8	M24/M22	188	175	176	3	4.5	28	120	68	160	6.3	12	6	11.06	10.27
150	168.3	159	300	250	26/25	8	M24/M22	218	203	204	3	4.5	30	145	72	186	7.1	12	6	14.16	13.30
(175)		194	350	295	30	8	M27	258	233	234	3	4.5	36	177	88	226	7.1	12	6	21.80	20.97
200	219.1	219	375	320	30	12	M27	282	259	260	3	4.5	38	200	88	250	8	16	8	25.56	24.72
(225)		245	415	355	34	12	M30	315	286	287	3	4.5	40	226	98	280	8	16	8	32.48	31.60
250	273	273	450/445	385	34	12	M30	345	312	313	3	4.5	42	252	102	310	10	18	10	39.87	39.00
300	323.9	325	515/510	450	34	12	M30	408	363	364	4	4.5	46	301	116	368	10	18	10	55.97	53.21
350	355.6	377	580/570	510	36/34	16	M33/M30	465	421	422	4	5	52	351	120	418	11	20	10	75.30	72.29
400	406.4	426	660/655	585	41	16	M36	535	473	474	4	5	58	398	142	480	12.5	20	10	112.02	108.44
450	457	480	685/680	610	41	20	M36	560	523	524	4	5	60	448	146	530	14.2	20	12	112.82	109.70
500	508	530	755	670	42/48	20	M39/M42	612	575	576	4	5	62	495	156	580	16	20	12	142.70	138.60
600	610	630	890	795	48/54	20	M45/M48	730	675/677/676/678	678	5	6	62	595	176	700	17.5	20	20	167	160参考
700	711	720	995	900	48/54	24	M45/M48	835	777/767/778/768	768	5	6	68	680	200	780	19	20	20	275	265参考
800	813	820	1140/1135	1030	58	24	M52	960	882/875/883/876	876	5	6	76	780	220	910	20	20	22	410	400参考

※系列1国家标准GB/T9119-2000/系列2机械行业标准JB/T81-94

表6 PN6.3MPa (64压力) 凹凸面对焊钢制管法兰 mm

公称 口径 DN	管子外径 A1		连接尺寸					密封面尺寸					法兰颈					法兰理论 重量系列 2 kg			
	国际 A管	国内 B管	法兰外径 系列1/ 系列2 D	螺栓 孔中 心直 径 K	螺栓孔 直径 系列1/ 系列2 L	螺栓、螺柱		d	X凸面 系列1/ 系列2	Y凹面 系列1/ 系列2	f	f1 f2	法兰 厚度 C	法兰 内径 B	法兰 高度 H	颈部 直径 Nmax	法兰 壁厚 S	直边 段 H1	圆角 半径 R	A型	B型
						数量 n	螺纹Th. 系列1/ 系列2														
10	17.2	14	100	70	14	4	M12	50	34	35	2	4	18	8	48	34	3	6	3	1.12	1.02
15	21.3	18	105	75	14	4	M12	55	39	40	2	4	18	12	48	38	3.2	6	3	1.25	1.14
20	26.9	25	130/125	90	18	4	M16	68	50	51	2	4	20	18	56	48	3.6	6	4	2.12	1.95
25	33.7	32	140/135	100	18	4	M16	78	57	58	2	4	22	25	58	52	3.6	8	4	2.64	2.46
32	42.4	38	155/150	110	23	4	M20	82	65	66	2	4	24	31	62	64	3.6	8	5	3.50	3.28
40	48.3	45	170/165	125	23	4	M20	95	75	76	3	4	24	37	68	74	4	10	5	4.35	3.91
50	60.3	57	180/175	135	23	4	M20	105	87	88	3	4	26	47	70	86	5	10	5	5.29	4.80
65	76.1	76	205/200	150	23	8	M20	130	109	110	3	4	28	64	75	106	6	12	6	7.00	6.43
80	88.9	89	215/210	170	23	8	M20	140	120	121	3	4	30	77	75	120	6	12	6	8.07	7.50
100	114.3	108	250	200	26/25	8	M24/M22	168	149	150	3	4.5	32	94	80	140	7	12	6	11.51	10.80
125	139.7	133	295	240	30	8	M27	202	175	176	3	4.5	36	118	98	172	7.5	12	6	18.02	17.09
150	168.3	159	345/340	280	34	8	M30	240	203	204	3	4.5	38	142	108	206	8.5	12	8	26.45	25.29
(175)		194	375/370	310	34	12	M30	270	233	234	3	4.5	42	174	110	232	8.5	12	8	30.63	29.61
200	219.1	219	415/405	345	36/34	12	M33/M30	300	259	260	3	4.5	44	198	116	264	10.5	16	8	39.63	38.51
(225)		245	430	370	36/34	12	M33/M30	325	286	287	3	4.5	46	222	120	290	10.5	16	8	43.34	42.32
250	273	273	470	400	36/41	12	M33/M36	352	312	313	3	4.5	48	246	122	316	13.5	18	10	53.64	52.47
300	323.9	325	530	460	36/41	16	M33/M36	412	363	364	4	4.5	54	294	136	370	15.5	18	10	73.10	69.97
350	355.6	377	600/595	525	41	16	M36	475	421	422	4	5	60	342	154	430	17.5	20	10	103.50	100.10
400	406.4	426	670	585	42/48	16	M39/M42	525	473	474	4	5	66	386	170	484	20	20	10	143.30	138.90
450	457	480	715	630	48	20	M42	570	523	524	4	5	70	440	186	540	22.5	22	15	160	155参考
500	508	530	800	705	48/54	20	M45	640	575	576	4	5	70	485	200	595	22.5	22	18	215	210参考
600	610	630	930	820	58	20	M52	750	675/677/676/678	678	5	6	76	585	220	710	25	22	18	320	310参考
700	711	720	1045	935	58	24	M52	865	777/767/778/768	768	5	6	84	670	240	800	25	24	18	450	435参考
800	813	820	1165	1050	62	24	M56	980	882/875/883/876	876	5	6	90	765	260	925	25	24	18	540	525参考

※系列1国家标准GB/T9119-2000/系列2机械行业标准JB/T81-94

**FLANGE  
PARAMETER TABLE**  
法兰参数对照表

**FLANGE  
PARAMETER TABLE**  
法兰参数对照表

表7 PN10.0MPa (100压力) 凹凸面对焊钢制管法兰 mm

公称 通径 DN	管子外径 A1		连接尺寸					密封面尺寸				法兰颈				法兰理论 重量系列 2 kg					
	国际 A管	国内 B管	法兰外径 系列1/ 系列2 D	螺栓 孔中 心圆 直径 K	螺栓孔 直径 系列1/ 系列2 L	螺栓、螺柱 数量 n	螺栓 Th. 系列1/ 系列2	d	X凸面 系列1/ 系列2	Y凹面 系列1/ 系列2	f	f1/2	法兰 厚度 C	法兰 内径 B	法兰 高度 H	颈部 直径 Nmax	法兰 焊端 壁厚 S	直边 段 H1	圆角 半径 R	A型	B型
10	172	14	100	70	14	4	M12	50	34	35	2	4	18	8	45	34	3	6	3	1.12	1.01
15	213	18	105	75	14	4	M12	55	39	40	2	4	20	12	48	38	3.2	6	3	1.37	1.26
20	269	25	130/125	90	18	4	M16	68	50	51	2	4	22	18	56	48	3.6	6	4	2.30	2.13
25	337	32	140/125	100	18	4	M16	78	57	58	2	4	24	25	58	52	3.6	8	4	2.86	2.67
32	424	38	155/150	110	23	4	M20	82	65	66	2	4	24	31	62	64	3.6	8	5	3.50	3.28
40	483	45	170/165	125	23	4	M20	95	75	76	3	4	26	37	70	76	4	10	5	4.72	4.28
50	603	57	195	145	26/25	4	M24/M22	112	87	88	3	4	28	45	72	86	6	10	5	6.58	6.02
65	761	76	220	170	26/25	8	M24/M22	138	109	110	3	4	32	62	84	110	7	12	6	9.20	8.60
80	889	89	230	180	26/25	8	M24/M22	148	120	121	3	4	34	75	90	124	7	12	6	10.61	9.97
100	1143	108	265	210	30	8	M27	172	149	150	3	4.5	38	92	100	146	8	12	6	15.54	14.70
125	1397	133	315/310	250	34	8	M30	210	175	176	3	4.5	42	112	115	180	10.5	12	6	25.10	24.00
150	1683	159	355/350	290	34	12	M30	250	203	204	3	4.5	46	136	130	214	11.5	12	8	34.43	33.26
(175)		194	385/380	320	34	12	M30	280	233	234	3	4.5	48	166	135	246	11.5	16	10	41.60	40.47
200	2191	219	430	360	36/41	12	M33/M36	312	259	260	3	4.5	54	190	145	276	14.5	16	10	57.14	55.80
(225)		245	470	400	41	12	M36	352	286	287	3	4.5	56	212	165	312	14.5	16	10	73.30	71.90
250	273	273	505/500	430	41	12	M36	382	312	313	3	4.5	60	236	170	340	18.5	18	10	89.30	87.90
300	323.9	325	585	500	42/48	16	M39/M42	442	363	364	4	4.5	70	284	195	400	20.5	18	12	137.45	130.10
350	355.6	377	665	560	48/54	16	M45/M48	498	421	422	4	5	76	332	210	460	22.5	20	12	186.00	175.20
400	406.4	426	715	620	48/54	16	M45/M48	558	473	474	4	5	80	376	220	510	25	20	12	223.50	218.50
450	457	480	770	675	58	20	M52	615	523	524	4	5	84	430	235	570	25	20	18	280	270参考
500	508	530	870	760	58	20	M52	690	575	576	4	5	90	465	245	600	30	22	18	350	335参考
600	610	630	990	875	58	24	M52	800	675/677	676/678	5	6	95	570	265	700	30	22	18	460	445参考

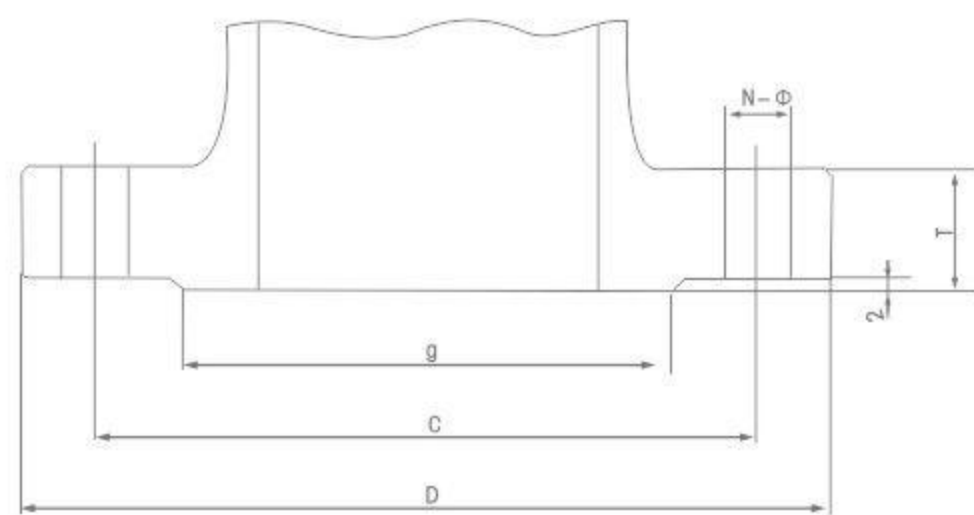

GB/T PN16 / PN40(RF)steel

※系列1国家标准GB/T9119-2000/系列2机械行业标准JB/T81-94

表8 PN2.0MPa (Class 150) 美标带颈平焊钢制管法兰 mm

公称 通径 NPS (in)	DN	钢管 外径 A	连接尺寸					密封面尺寸		法兰 厚度 C	法兰 内径 B	法兰颈 N	法兰 高度 H	理论 重量 kg
			法兰 外径 D	螺栓孔 中心圆 直径K	螺栓孔 直径 L	螺栓孔 数量n	螺纹 Th.	突面d	台高f1					
1/2	15	21.3	89	60.5	16	4	M14	35	1.6	11.5	22	30	16	0.41
3/4	20	26.9	98	70	16	4	M14	43	1.6	13	27.5	38	16	0.58
1	25	33.7	108	79.5	16	4	M14	51	1.6	14.5	34.5	49	17	0.80
1 1/4	32	42.4	117	89	16	4	M14	63.5	1.6	16	43.5	59	21	1.07
1 1/2	40	48.3	127	98.5	16	4	M14	73	1.6	17.5	49.5	65	22	1.37
2	50	60.3	152	120.5	18	4	M16	92	1.6	19.5	61.5	78	25	2.01
2 1/2	65	76.1	178	139.5	18	4	M16	105	1.6	22.5	77.5	90	29	3.32
3	80	88.9	190	152.5	18	4	M16	127	1.6	24	90.5	108	30	3.83
4	100	114.3	229	190.5	18	8	M16	157.5	1.6	24	116	135	33	5.40
5	125	139.7	254	216	22	8	M20	186	1.6	24	141.5	164	36	6.26
6	150	168.3	274	241.5	22	8	M20	216	1.6	25.5	170.5	192	40	7.50
8	200	219.1	343	298.5	22	8	M20	270	1.6	29	221.5	246	44	12.3
10	250	273	406	362	26	12	M24	324	1.6	30.5	276.5	305	49	16.2
12	300	323.9	483	432	26	12	M24	381	1.6	32	327.5	365	56	26.5
14	350	355.6	533	476	29.5	12	M27	413	1.6	35	359.5	400	57	34.5
16	400	406.4	597	540	29.5	16	M27	470	1.6	37	411	457	64	45.5
18	450	457	635	578	32.5	16	M30	533.5	1.6	40	462	505	68	48.5
20	500	508	698	635	32.5	20	M30	584	1.6	43	513.5	559	73	61.8
24	600	610	813	749.5	35.5	20	M33	692	1.6	48	616.5	664	83	87.7

表9 PN5.0MPa (Class 300) 美标带颈平焊钢制管法兰 mm

公称 通径 NPS (in)	DN	钢管 外径 A	连接尺寸					密封面尺寸		法兰 厚度 C	法兰 内径 B	法兰颈 N	法兰 高度 H	理论 重量 kg
			法兰 外径 D	螺栓孔 中心圆 直径K	螺栓孔 直径 L	螺栓孔 数量n	螺纹 Th.	突面d	台高f1					
1/2	15	21.3	89	66.5	16	4	M14	35	1.6	14.5	22	38	22	0.63
3/4	20	26.9	117	82.5	18	4	M16	43	1.6	16	27.5	48	25	1.16
1	25	33.7	124	89	18	4	M16	51	1.6	17.5	34.5	54	27	1.37
1 1/4	32	42.4	133	98.5	18	4	M16	63.5	1.6	19.5	43.5	64	27	
1 1/2	40	48.3	156	114.5	22	4	M20	73	1.6	21	49.5	70	30	
2	50	60.3	165	127	18	8	M16	92	1.6	22.5	61.5	84	33	
2 1/2	65	76.1	190	149	22	8	M20	105	1.6	25.5	77.5	100	38	
3	80	88.9	210	168.5	22	8	M20	127	1.6	29	90.5	118	43	
4	100	114.3	254	200	22	8	M20	157.5	1.6	32	116	146	48	
5	125	139.7	279	235	22	8	M20	186	1.6	35	141.5	178	51	
6	150	168.3	318	270	22	12	M20	216	1.6	37	170.5	206	52	
8	200	219.1	381	330	26	12	M24	270	1.6	41.5	221.5	260	62	
10	250	273	444	387.5	29.5	16	M27	324	1.6	48	276.5	321	67	
12	300	323.9	521	451	32.5	16	M30	381	1.6	51	327.5	375	73	
14	350	355.6	584	514.5	32.5	20	M30	413	1.6	54	359.5	426	76	
16	400	406.4	648	571.5	35.5	20	M33	470	1.6	57.5	411	483	83	
18	450	457	711	628.5	35.5	24	M33	533.5	1.6	60.5	462	533	89	
20	500	508	775	686	35.5	24	M33	584	1.6	63.5	513.5	587	95	
24	600	610	915	813	42	24	M39×3	692	1.6	70	616.5	702	104	

※系列1国家标准GB/T9119-2000/系列2机械行业标准JB/T81-94

# FLANGE PARAMETER TABLE

## 法兰参数对照表

# MATERIAL CHEMICAL COMPOSITION LIST

## 材质化学成分表

表10 PN11.0MPa ( Class 600 ) 美标带颈平焊钢制管法兰 mm

公称 通径 NPS (in)	DN	钢管 外径 A	连接尺寸					密封面尺寸		法兰 厚度 C	法兰 内径 B	法兰 颈 N	法兰 高度 H	理论 重量 kg
			法兰 外径 D	螺栓孔 中心圆 直径K	螺栓孔 直径 L	螺栓孔 数量n	螺纹 Th.	突面d	台高f1					
1/2	15	21.3	95	66.5	16	4	M14	35	6.4	14.5	14	38	52	1.35
3/4	20	26.9	118	82.5	18	4	M16	43	6.4	16	18.5	48	57	1.59
1	25	33.7	124	89	18	4	M16	51	6.4	17.5	24.5	54	62	1.82
1 1/4	32	42.4	133	98.5	18	4	M16	63.5	6.4	21	32	64	67	2.50
1 1/2	40	48.3	156	114.5	22	4	M20	73	6.4	22.5	38	70	70	3.63
2	50	60.3	165	127	18	8	M16	92	6.4	25.5	49	84	73	4.54
2 1/2	65	76.1	190	149	22	8	M20	105	6.4	29	61.5	100	79	6.36
3	80	88.9	210	168.5	22	8	M20	127	6.4	32	72.5	117	83	8.17
4	100	114.3	273	216	26	8	M24	157.5	6.4	38.5	96.5	152	102	16.8
5	125	139.7	330	267	29.5	8	M27	186	6.4	44.5	119.5	189	114	30.9
6	150	168.3	356	292	29.5	12	M27	216	6.4	48	146	222	117	33.1
8	200	219.1	419	349	32.5	12	M30	270	6.4	55.5	187	273	133	50.9
10	250	273	508	432	35.5	16	M33	324	6.4	63.5	238	343	152	85.8
12	300	323.9	560	489	35.5	20	M33	381	6.4	67	279.5	400	156	102.6
14	350	355.6	605	527	39	20	M36×3	413	6.4	70	305.5	432	165	157.5
16	400	406.4	685	603	42	20	M39×3	470	6.4	76.5	350	495	178	218.4
18	450	457	745	654	45	20	M42×3	533.5	6.4	83	397	546	184	252.0
20	500	508	815	724	45	24	M42×3	584	6.4	89	444	610	190	313.3
22	550	559	870	778	48	24	M45×3	641	6.4	95	487	665	197	376.5
24	600	610	940	838	51	24	M48×3	692	6.4	102	530	718	203	443.6

材质化学成分表 Material chemical composition list

ASTM	化学成份%											抗拉屈服				硬度	屈服强度
	C ≤	Mn ≤	P ≤	S ≤	Si ≤	Cr ≤	Mo ≤	Ni ≤	Cu ≤	V ≤	Nb ≤	收缩率 MPa, ≥	延伸率 MPa, ≥	收缩率 %, ≥	延伸率 %, ≥	布氏硬度 Hb, ≤	J, ≥
A105	0.35	0.60-1.05	0.035	0.040	0.10-0.35	0.30	0.12	0.4	0.40	0.08	0.02	485	250	30	30	187	
A182 F11	0.05-0.15	0.30-0.60	0.030	0.030	0.50-1.00	100-150	0.44-0.65					415	205	20	45	121-174	
A182 F22	0.05-0.15	0.30-0.60	0.040	0.040	0.5	200-250	0.87-1.13					415	205	20	35	170	
A182 F304	0.08	2.00	0.045	0.030	1.00	180-200		80-110				515	205	30	50		
A182 F304L	0.030	2.00	0.045	0.030	1.00	180-200		80-130				485	170	30	50		
A182 F316	0.08	2.00	0.045	0.030	1.00	160-180	200-300	100-140				515	205	30	50		
A182 F316L	0.030	2.00	0.045	0.030	1.00	160-180	200-300	100-150				485	170	30	50		
A182 F51	0.030	2.00	0.030	0.020	1.00	210-230	25-35	45-65				620	450	25	45		
A182 F6a	0.15	1.00	0.040	0.030	1.00	115-135		0.50				585	380	18	35	167-229	
A93 B7	0.37-0.49	0.65-1.10	0.035	0.040	0.15-0.35	0.75-1.20	0.15-0.25					860	720	16	50	321	
A193 B7M	0.37-0.49	0.65-1.10	0.035	0.040	0.15-0.35	0.75-1.20	0.15-0.25	80-110				690	550	18	50	235	
A193 B8	0.08	2.00	0.045	0.030	1.00	180-200		100-140		0.25-0.35		515	205	30	50	223	
193 B8M	0.08	2.00	0.045	0.030	1.00	160-180	200-300					515	205	30	50	223	
A193 B16	0.36-0.47	0.45-0.70	0.035	0.040	0.15-0.35	0.80-1.15	0.50-0.65					860	720	18	50	321	
A194 2H	≥0.40	1.00	0.040	0.050	0.04											248-352	
A194 2HM	≥0.40	1.00	0.040	0.050	0.04			80-110								159-237	
A194 8	0.08	2.00	0.045	0.030	1.00	180-200		100-140								126-300	
A194 BM	0.08	2.00	0.045	0.030	1.00	160-180	200-300									126-300	
A216 WCB	0.30	1.00	0.04	0.045	0.60	0.50	0.20	0.50	0.30	0.03		485-655	250	22	35		
A216 WCC	0.25	1.20	0.04	0.045	0.60	0.50	0.2	0.50	0.30	0.03		485-655	275	22	35		
A217 C5	0.20	0.40-0.70	0.04	0.045	0.75	400-650	0.45-0.65	0.50	0.50			620-795	415	18	35		
A217 CA15	0.15	1.00	0.040	0.040	1.50	115-140	0.50	1.00				620-795	450	18	30		
A217 WC6	0.05-0.20	0.50-0.80	0.04	0.045	0.60	100-150	0.45-0.65	0.50	0.50			485-655	275	20	35		
A217 WC9	0.05-0.18	0.40-0.70	0.04	0.045	0.60	200-275	0.90-1.20		0.50			480	275	20	35		
A276 410	0.08-0.15	1.00	0.040	0.030	1.00	115-135							275	20	45		
A276 420	≥15	1.00	0.040	0.030	1.00	120-140						860				241	
A320 L7	0.38-0.048	0.75-1.00	0.035	0.040	0.15-0.35	0.80-1.10	0.15-0.25					690	725	16	50		Avg27min20
A320 L7M	0.38-0.048	0.75-1.00	0.035	0.040	0.15-0.35	0.80-1.10	0.15-0.25					515-690	550	18	50	235	Avg27min20
A336 F22	0.05-0.15	0.30-0.60	0.025	0.025	0.5	200-250	0.90-1.10					415-585	310	19	40		
A350 LF1	0.30	0.60-1.35	0.035	0.040	0.15-0.30	0.30	0.12	0.40	0.40	0.08	0.02	415-585	205	28	38		Avg18min14
A350 LF2	0.30	0.60-1.35	0.035	0.040	0.15-0.30	0.30	0.12	0.40	0.40	0.08	0.02	485-655	250	30	30		Avg20min16
A351 CF8	0.08	1.50	0.040	0.040	2.00	180-210	0.50	80-110				485	205	35.0			
A351 CF3	0.03	1.50	0.040	0.040	2.00	170-210	0.50	80-120				485	205	35.0			
A351 CF8M	0.08	1.50	0.040	0.040	1.50	180-210	200-300	90-120				485	205	30.0			
A351 CF3M	0.03	1.50	0.040	0.040	1.50	170-210	200-300	90-130				485	205	30.0			
A351 CF8C	0.08	1.50	0.040	0.040	2.00	180-210	0.50	90-120	30-40			485	205	30.0			
A351 CN7M	0.07	1.50	0.040	0.040	1.50	190-220	200-300	275-305				425	170	35			
A352 LC1	0.25	0.50-0.80	0.04	0.045	0.60		0.45-0.65					450-620	240	24	35		
A352 LC2	0.25	0.50-0.80	0.04	0.045	0.60			200-300				485-655	275	24	35		Avg18min14
A352 LC3	0.15	0.50-0.80	0.04	0.045	0.60			300-400				485-655	275	24	35		Avg20min16
A352 LCB	0.30	1.00	0.04	0.045	0.60	0.50	0.20	0.50	0.30	0.30		450-620	240	24	35		Avg20min16
A352 LCC	0.25	1.20	0.04	0.045	0.60	0.50	0.20	0.50		0.30		485-655	275	22	35	139-202	Avg18min14
A439 D2	0.30	0.70-1.25	0.08		1.50-3.00	1.75-2.75		1800-2200				400	207	8.0			Avg20min16

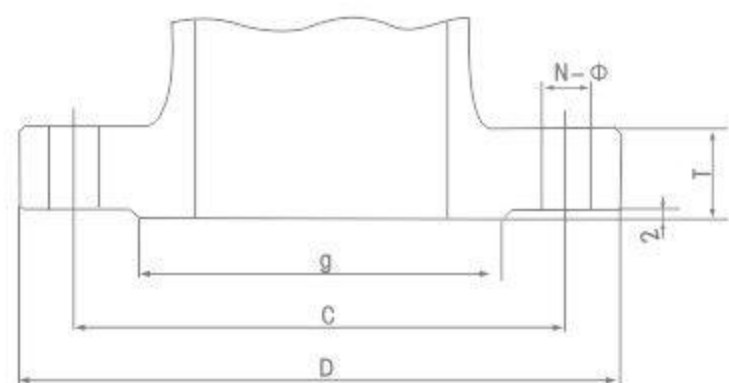

Class 150 / 300Lb (RF)Steel

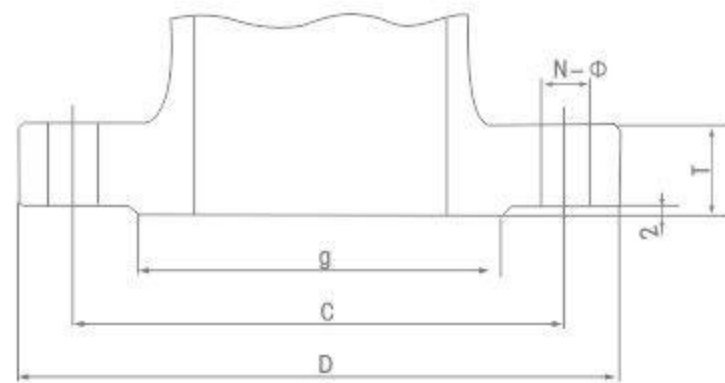

Class 600Lb (RF)Steel