

# THREADED SERIES 丝扣系列

# 08

## THREADED BALL VALVE

丝扣球阀

3PC Ball valve  
三片式球阀

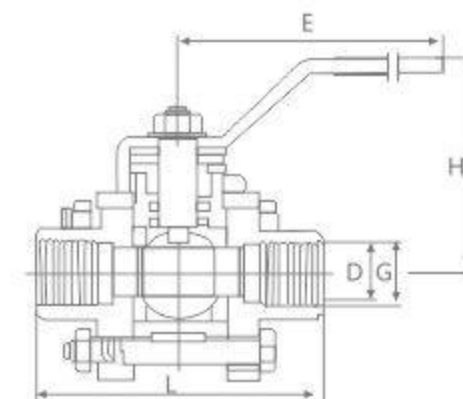

DN	G	D	L	H	E
6	1/4"	10	65	50	95
10	3/8"	12	65	50	95
15	1/2"	15	75	55	105
20	3/4"	20	80	60	120
32	1 1/4"	32	110	82	155
40	1 1/2"	38	120	90	170
50	2"	50	140	105	220
65	2 1/2"	64	160	120	245
80	3"	78	180	132	270
100	4"	100	215	160	315

3PC Ball Welding Ball valve  
三片式对焊球阀

Q61F-16  
64P

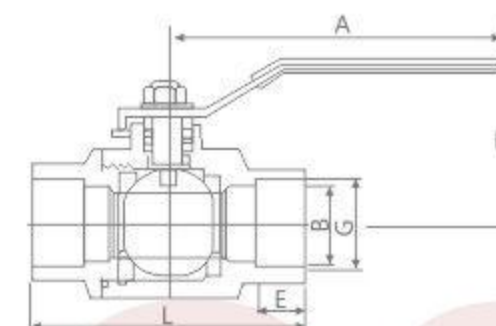

DN	G	B	L	H	A
6	1/4"	10	65	50	90
10	3/8"	12	65	50	90
15	1/2"	15	75	55	100
20	3/4"	20	80	60	120
25	1"	25	90	70	140
32	1 1/4"	32	110	82	140
40	2 1/2"	38	120	90	180
50	2"	50	140	105	200
65	2 1/2"	64	160	120	220
80	3"	78	180	132	240
100	4"	100	215	160	300

3PC Quick Install Ball valve  
三片式快装球阀

Q81F-(6-25)C, P, R

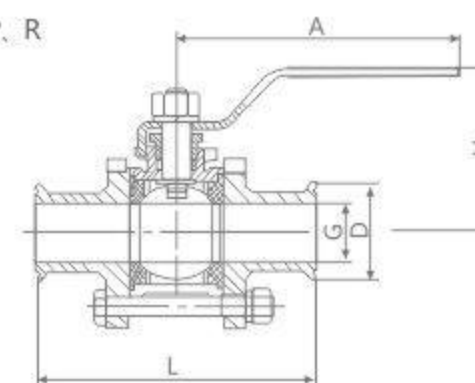

DN	G	D	L	H	A
15	1/2"	34	100	55	100
20	1/4"	50.5	100	60	120
25	1"	50.5	120	70	140
32	1 1/4"	50.5	130	82	140
40	1 1/2"	50.5	140	90	180
50	2"	64	156	105	200
65	2 1/2"	91	196	120	220
80	3"	106	228	132	240



# THREADED BALL VALVE

丝扣球阀

# THREADED BALL VALVE

丝扣球阀

3PC High Platform ThreadBall valve  
三片式高平台内螺纹球阀

Q11F-16P  
64

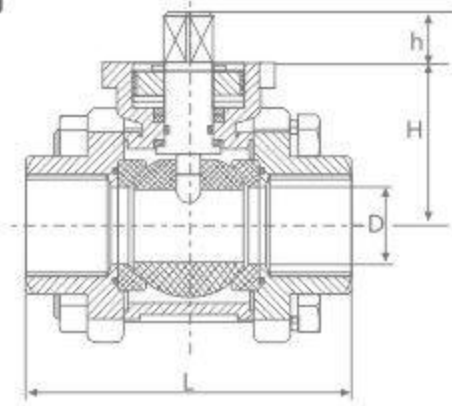

DN	G	D	L	H	W
6	1/4"	8	65	66	100
10	3/8"	10	65	66	100
15	1/2"	14	75	66	100
20	3/4"	20	80	73	115
25	1"	25	90	81	140
32	1 1/4"	32	110	91	140
40	1 1/2"	38	120	105	180
50	2"	50	140	113	190
65	2 1/2"	65	170	155	233
80	3"	76	186	164	233
100	4"	94	220	170	233

2PC Ball valve  
二片式球阀

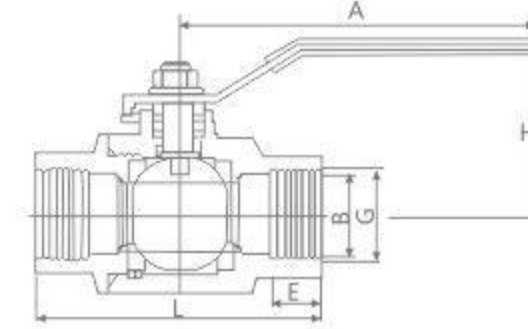

DN	G	B	L	E	H	A
6	1/4"	10	55	11.5	50	95
10	3/8"	12	55	11.5	50	95
15	1/2"	15	57	14	55	105
20	3/4"	20	65	15	65	120
25	1"	25	79	15	72	140
32	1 1/4"	32	90	18	80	155
40	1 1/2"	38	98	19	95	170
50	2"	50	116	19	105	185
65	2 1/2"	65	148	23	120	220

Three-Ball valve Live Then Surfacing  
三片式活接对焊式不锈钢球阀

Q21F-16P  
64

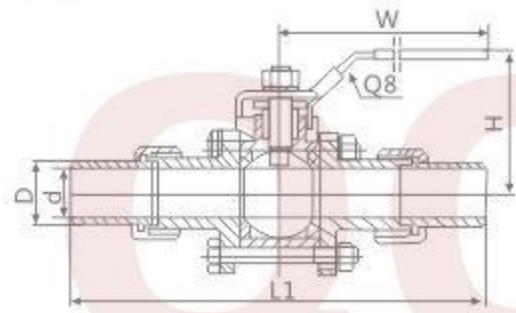

G	d	D	L1	H	W
1/4"	11.6	17	150	48	120
3/8"	12.7	17	150	48	120
1/2"	15	21	170	54	120
3/4"	20	26	185	57	130
1"	25	31	200	72	154
1 1/4"	32	38	225	49	154
1 1/2"	38	46	260	81	185
2"	50.8	60	300	97	185

Female Three Ball valve  
内螺纹三通球阀

Q15F-16P  
64

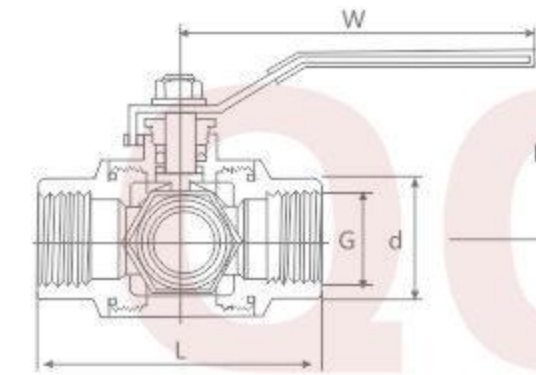

DN	G	L	d	W	H
6	1/4"	71	10	110	56
10	3/8"	71	12	110	56
15	1/2"	74	12	110	58
20	3/4"	88	15	120	60
25	1"	92	20	140	70
32	1 1/4"	124	25	140	82
40	2 1/2"	138	32	180	95
50	2"	154	38	200	100

1PC Ball valve  
一片式球阀

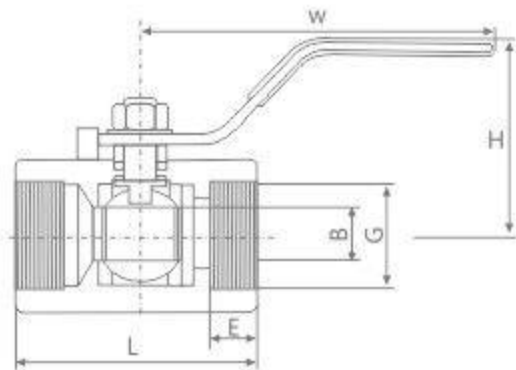

DN	G	B	L	E	H	W
10	3/8"	6	45	13	36	70
15	1/2"	9	55	16	39	80
20	3/4"	12	60	18	43	90
25	1"	15	70	20	46	105
32	1 1/2"	20	80	21.5	53	120
40	1 1/4"	25	86	23	59	130
50	2"	32	101	24.5	65	145

Three-way High Platform Internal Thread Ball valve  
三通高平台内螺纹球阀

Q15F-16P  
64

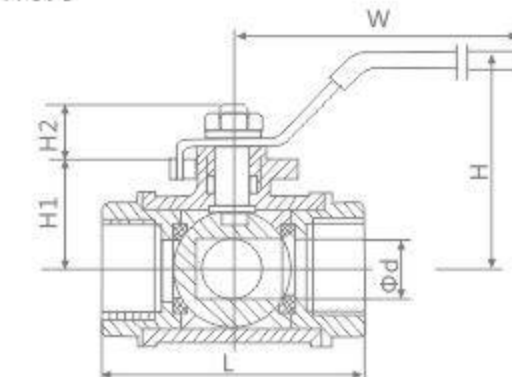

DN	d	L	H	H1	H2	W	ISO5211
1/2"	12	74	58	42	9	145	F03-F04
3/4"	15	88	60	49	9	145	F03-F05
1"	20	92	70	60	11	170	F04-F05
1 1/4"	25	124	82	63	11	170	F04-F07
1 1/2"	32	135	95	74	14	210	F05-F07
2"	38	154	100	83	14	210	F05-F07

Z15W Gate valve  
Z15W闸阀  
Z15W-16<sup>P</sup><sub>R</sub>

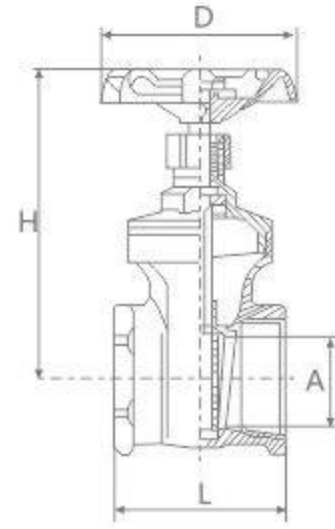

**技术规范 Technique norm**

公称压力: 1.6MPa  
适合介质: 水、油、气  
适合温度: 常温下1.6MPa饱和蒸汽下1.0MPa  
压力实验符合ISO5208,圆锥管螺纹符合ISO07标准中的Rc螺纹-G·NPT·  
Nominal pressure: 1.6MPa  
Suitable for medium: water, oil and gas  
Suitable temperature: 1.6MPa at room temperature and 1.0MPa at steam  
Pressure test in accordance with ISO5208, conical thread in accordance with ISO07 standard Rc thread -G·NPT·

SIZE	1/2"	3/4"	1"	1 1/4"	1 1/2"	2"
A	15	20	25	32	38	50
H	90	98	108	128	152	166
L	55	60	68	76	80	93
D	70	70	80	80	100	100

J11W Globe valve  
J11W截止阀  
J11W-16<sup>P</sup><sub>R</sub>

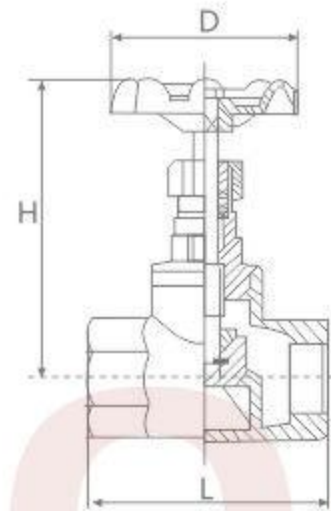

**技术规范 Technique norm**

公称压力: 1.6MPa  
适合温度: t ≤ 150°C  
压力实验符合ISO5208  
圆锥管螺纹符合ISO07标准中的Rc螺纹-G·NPT·  
Nominal pressure: 1.6MPa  
Applicable temperature: t ≤ 150°C  
Pressure test match ISO5208  
Lone tube the screw match ISO7 standard inside of Rc screw-G·NPT·

DN	15	20	25	32	40	50
SIZE	1/2"	3/4"	1"	1 1/4"	1 1/2"	2"
L	65	75	90	105	120	140
H	88	95	110	123	135	150
D	70	70	80	100	100	100

H14W Check valve  
H14W止回阀  
H14W-16<sup>P</sup><sub>R</sub>

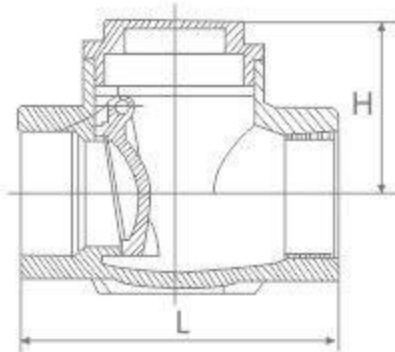

**技术规范 Technique norm**

公称压力: 1.6MPa  
适合介质: 水、油、气  
适合温度: t ≤ 150°C  
压力实验符合ISO5208,圆锥管螺纹符合ISO07标准中的Rc螺纹-G·NPT·  
Nominal pressure: 1.6MPa  
Applicable medium: water, oil, steam  
Applicable temperature: t ≤ 150°C  
Pressure test match ISO5208, Lone tube the screw match ISO7 standard inside of Rc screw-G·NPT·

DN	15	20	25	32	40	50
SIZE	1/2"	3/4"	1"	1 1/4"	1 1/2"	2"
L	65	75	90	105	120	140
H	42	46	54	58	66	74

**集生产、研发、销售、服务  
于一体阀门制造企业**

Set production, research and development,  
sales and service in one valve manufacturing enterprise