

FLANGED FLANGED BUTTERFLY VALVE (MIDDLE LINE)

衬氟法兰蝶阀(中线)

FLANGED FLANGED BUTTERFLY VALVE (MIDDLE LINE)

衬氟法兰蝶阀(中线)

主要连接尺寸及重量 Main connection dimensions and weight

JB/T82.1

公称通径DN		标准值Standard value							参考值Reference value		
DN (mm)	NPS (inch)	L	D	D1	D2	f	b	Z-Φd	D0	H	重量Weight(kg)
PN0.6MPa											
40	1 1/2	106	130	100	80	3	12	4-Φ14	160	140	10
50	2	108	140	110	90	3	12	4-Φ14	200	160	12
65	2 1/2	112	160	130	110	3	14	4-Φ14	250	160	13
80	3	114	185	150	125	3	14	4-Φ18	250	170	14
100	4	127	205	170	145	3	14	4-Φ18	250	180	16
125	5	140	235	200	175	3	14	8-Φ18	300	275	18
150	6	140	260	225	200	3	16	8-Φ18	300	295	38
200	8	152	315	280	255	3	18	8-Φ18	200*	320	74
250	10	250	370	335	310	3	22	12-Φ18	200*	385	105
300	12	270	435	395	362	4	22	12-Φ23	240*	390	142
350	14	290	485	445	412	4	22	12-Φ23	240*	460	179
400	16	310	535	495	462	4	22	16-Φ23	280*	510	220
450	18	330	590	550	518	4	24	16-Φ23	280*	540	268
500	20	350	640	600	568	4	24	16-Φ23	320*	570	378
600	24	390	755	705	670	5	24	20-Φ25	320*	660	608
700	28	430	860	810	775	5	26	24-Φ25	360*	710	1050
800	32	470	975	920	880	5	26	24-Φ30	360*	780	1320
900	36	510	1075	1020	980	5	28	24-Φ30	380*	885	1795
1000	40	550	1175	1120	1080	5	30	28-Φ30	400*	990	1900
1200	48	630	1375	1320	1280	5	30	32-Φ30	400*	1170	2110
PN1.0MPa											
40	1 1/2	106	145	110	85	3	18	4-Φ18	160	140	10
50	2	108	160	125	100	3	18	4-Φ18	200	160	12
65	2 1/2	112	180	145	120	3	20	4-Φ18	250	165	13
80	3	114	195	160	135	3	20	8-Φ18	250	170	14
100	4	127	215	180	155	3	22	8-Φ18	250	180	16
125	5	140	245	210	185	3	24	8-Φ18	300	275	18
150	6	140	280	240	210	3	24	8-Φ23	300	295	38
200	8	152	335	295	265	3	24	8-Φ23	200*	320	74
250	10	250	390	350	320	3	26	12-Φ23	200*	385	105
300	12	270	440	400	368	4	28	12-Φ23	240*	390	142
350	14	290	500	460	428	4	28	16-Φ23	240*	460	179
400	16	310	565	515	482	4	30	16-Φ25	280*	510	220
450	18	330	615	565	532	4	30	20-Φ25	280*	540	268
500	20	350	670	620	585	4	32	20-Φ25	320*	570	378
600	24	390	780	725	685	5	36	20-Φ30	320*	660	608
700	28	430	895	840	800	5	40	24-Φ30	360*	710	1050
800	32	470	1010	950	905	5	44	24-Φ34	360*	780	1320
900	36	510	1110	1050	1005	5	46	28-Φ34	380*	885	1795
1000	40	550	1220	1160	1115	5	50	28-Φ34	400*	990	1900
1200	48	630	1450	1380	1325	5	56	32-Φ41	400*	1200	2150

法兰尺寸PN1.0MPa, DN80螺孔数量JB78时Z=4,其它标准时Z=8。
Flange size PN1.0MPa, DN80 screw when the number of JB78 Z = 4, other standards, Z = 8.

主要连接尺寸及重量 Main connection dimensions and weight

JB/T79.1

公称通径DN		标准值Standard value							参考值Reference value		
DN (mm)	NPS (inch)	L	D	D1	D2	f	b	Z-Φd	D0	H	重量Weight(kg)
PN1.6MPa											
40	1 1/2	106	145	110	85	3	16	4-Φ18	160	140	10
50	2	108	160	125	100	3	16	4-Φ18	200	160	12
65	2 1/2	112	180	145	120	3	18	4-Φ18	250	160	13
80	3	114	195	160	135	3	20	8-Φ18	260	170	14
100	4	127	215	180	155	3	20	8-Φ18	300	180	16
125	5	140	245	210	185	3	22	8-Φ18	300	275	18
150	6	140	280	240	210	3	24	8-Φ23	200*	295	42
200	8	152	335	295	265	3	26	12-Φ23	200*	320	78
250	10	250	405	355	320	3	30	12-Φ25	240*	385	120
300	12	270	460	410	375	4	30	12-Φ25	240*	390	145
350	14	290	520	470	435	4	34	16-Φ25	240*	460	202
400	16	310	580	525	485	4	36	16-Φ30	280*	510	235
450	18	330	640	585	545	4	40	20-Φ30	280*	540	368
500	20	350	705	650	608	4	44	20-Φ34	320*	570	420
600	24	390	840	770	718	5	48	20-Φ41	320*	660	750
700	28	430	910	840	788	5	50	24-Φ41	360*	710	1028
800	32	470	1020	950	898	5	52	24-Φ41	380*	780	1690
900	36	510	1120	1050	998	5	54	28-Φ41	400*	885	1815
1000	40	550	1255	1170	1110	5	56	28-Φ48	500*	990	2050

JB/T79.1

公称通径DN		标准值Standard value							参考值Reference value		
DN (mm)	NPS (inch)	L	D	D1	D2	f	B	Z-Φd	D0	H	重量Weight(kg)
PN2.5MPa											
40	1 1/2	106	145	110	85	3	18	4-Φ18	200	140	11
50	2	108	160	125	100	3	20	4-Φ18	200	160	13
65	2 1/2	112	180	145	120	3	22	8-Φ18	250	160	14
80	3	114	195	160	135	3	22	8-Φ18	250	170	16
100	4	127	230	190	160	3	24	8-Φ23	300	180	18
125	5	140	270	220	188	3	28	8-Φ25	300	275	20
150	6	140	300	250	218	3	30	8-Φ25	240*	295	48
200	8	152	360	310	278	3	34	12-Φ25	240*	320	88
250	10	250	425	370	332	3	36	12-Φ30	280*	385	145
300	12	270	485	430	390	4	40	16-Φ30	280*	390	157
350	14	290	550	490	448	4	44	16-Φ34	320*	460	222
400	16	310	610	550	505	4	48	16-Φ34	320*	510	353
450	18	330	660	600	555	4	50	20-Φ34	360*	540	405
500	20	350	730	660	610	4	52	20-Φ41	360*	570	448
600	24	390	840	770	718	5	56	20-Φ41	380*	660	795

集生产、研发、销售、服务
于一体阀门制造企业

Set production, research and development,
sales and service in one valve manufacturing enterprise

产品选型手册
Product selection manual

07

FLUORINE LINED
VALVE SERIES
衬氟阀门系列



FLUORINE FLANGED GLOBE VALVE

衬氟法兰截止阀

FLUORINE FLANGED GLOBE VALVE

衬氟法兰截止阀

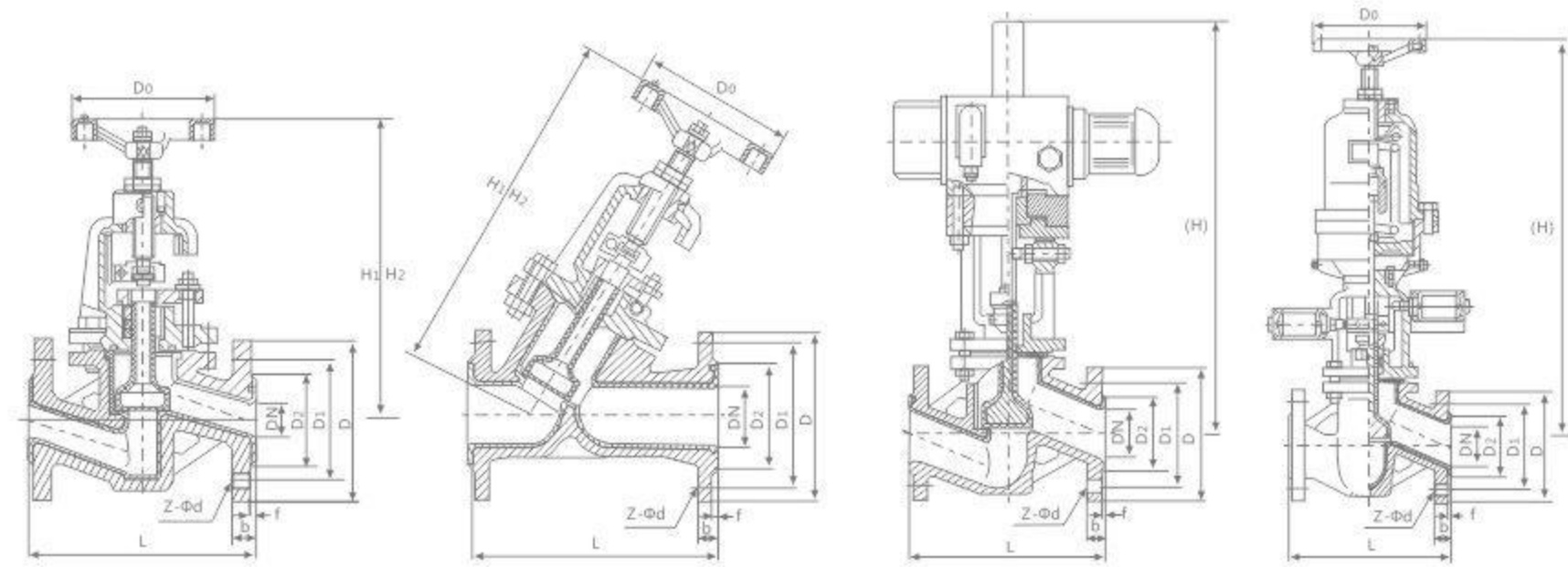

J41 F₃ F₄₆ 型Type 法兰连接手动截止阀 (直通式) Flange connection manual cut-off valve (straight-through)
 J45 F₃ F₄₆ 型Type 法兰连接手动截止阀 (直流式) Flange connection manual cut-off valve (DC type)
 J941 F₃ F₄₆ 型Type 法兰连接电动截止阀 (直通式) Flange connection electrically operated cut-off valve (straight-through)
 J6B41 F₃ F₄₆ 型 法兰连接气动截止阀 (常闭式) Flange connection air operated cut-off valve (Normally closed)

遵循规范 Follow the standard	STANDARD
设计与制造 Design and manufacture	GB 12233/GB 12235
结构长度 Structure Length	GB 12221(长—短系列Long - Short Series)
法兰尺寸 Flange size	GB/T9113.1、GB/T17241.6 (或按合同要求Or by contract requirement)
压力试验 Pressure test	GB/T 13927
标志 Mark	GB 12220
供货 Availability	GB/T 12252

法兰连接截止阀 Flange connection cut-off valve

※设计与制造符合中国国家标准
 ※Design and manufacture comply with national standards of China
 ※基本结构形式：直通式、直流式
 ※Basic structure form: Straight-through, DC type
 ※公称压力PN1.0~2.5MPa
 ※Nominal pressure PN1.0~2.5MPa
 ※公称口径DN15~350mm
 ※Nominal size DN15~350mm

基本型号 (全衬里) The basic model (full lining)

手动 Hand	J41F ₃ J41F ₄₆	齿轮 传动 Gear drive	J441F ₃ J441F ₄₆
气动 Pneumatic	J6B41F ₃ J6B41F ₄₆	电动	J941F ₃ J941F ₄₆

主要零部件材料表 Main spare part bill of materials

序号 NO.	零件名称 Part name	灰铸铁 Grey cast iron	碳钢 Carbon Steel	不锈钢 Stainless steel		超低碳不锈钢 Low Carbon Stainless Steel	
		Z	C	P	R	PL	RL
1	阀体、阀盖 Body, cover	HT250	WCB	CF8	CF8M	CF3	CF3M
2	阀瓣、阀杆 Disc, stem	35	1Cr13	0Cr18Ni9	0Cr1Ti12Mo2	00Cr18Ni10	00Cr17Ni14Mo2
3	活节螺栓 Live bolts	35	35	1Cr17Ni2	1Cr17Ni2	1Cr17Ni2	1Cr17Ni2
4	衬里层/阀座 Lining level/ seat	FEP(F46) PCTFE(F3) PTFE(F4) PFA (可溶性聚四氟乙烯Soluble PTFE) Po (聚烯烃Polyolefin)					
5	填料 Packing	PTFE(F4)					
6	填料压盖 Packing cover	WCB	WCB	CF8	CF8M	CF3	CF3M
7	阀杆螺母 Stem nut	ZCuAl10Fe3					
8	螺栓 Bolt	35	35	1Cr17Ni2	1Cr17Ni2	1Cr18Ni9Ti	1Cr18Ni9Ti
9	螺母 Nut	45	45	0Cr18Ni9	0Cr18Ni9	0Cr18Ni9	0Cr18Ni9
10	手轮 Hand wheel	Ht200	Ht200	WCC	WCC	WCC	WCC

主要连接尺寸及重量 Main connection dimension and weight

公称口径DN DN (mm)	NPS (inch)	标准值 Standard value							参数值 Reference value			
		L	D	D1	D2	f	b	Z-Φd	D0	H1	H2	重量 (kg) Weight
PN1.0MPa												
15	1/2	130	95	65	45	2	12	4-Φ14	100	235	260	6.5
20	3/4	150	105	75	55	2	14	4-Φ14	100	240	265	7
25	1	160	115	85	65	2	14	4-Φ14	120	245	270	7.8
32	1 1/4	180	135	100	78	2	16	4-Φ18	140	255	285	11
40	1 1/2	200	145	110	85	3	18	4-Φ18	140	285	315	13
50	2	230	160	125	100	3	18	4-Φ18	160	295	330	15
65	2 1/2	290	180	145	120	3	20	4-Φ18	180	350	395	23
80	3	310	195	160	135	3	20	4/8-Φ18	240	395	445	38
100	4	350	215	180	155	3	22	8-Φ18	240	450	490	42
125	5	400	245	210	185	3	24	8-Φ18	280	525	555	55
150	6	480	280	240	210	3	24	8-Φ23	320	605	645	77
200	8	495	335	295	265	3	24	8-Φ23	360	645	765	135
250	10	622	390	350	320	3	26	12-Φ23	400	685	805	220
300	12	698	440	400	368	4	28	12-Φ23	400	710	814	277
350	14	787	500	460	428	4	28	16-Φ23	450	750	855	320
PN1.6MPa												
15	1/2	130	95	65	45	2	14	4-Φ14	100	240	265	7
20	3/4	150	105	75	55	2	14	4-Φ14	100	245	270	7.6
25	1	160	115	85	65	2	14	4-Φ14	120	250	275	8.2
32	1 1/4	180	135	100	78	2	16	4-Φ18	140	260	290	12
40	1 1/2	200	145	110	85	3	16	4-Φ18	140	285	320	14
50	2	230	160	125	100	3	16	4-Φ18	160	300	335	18
65	2 1/2	290	180	145	120	3	18	4-Φ18	180	355	400	26
80	3	310	195	160	135	3	20	8-Φ18	240	400	450	40
100	4	350	215	180	155	3	20	8-Φ18	240	455	495	50
125	5	400	245	210	185	3	22	8-Φ18	280	530	560	65
150	6	480	280	240	210	3	24	8-Φ23	320	610	650	85
200	8	495	335	295	265	3	26	12-Φ23	360	650	770	150
250	10	622	405	355	320	3	30	12-Φ25	400	690	810	245
300	12	698	460	410	375	4	30	12-Φ25	400	730	845	295
PN2.5MPa												
15	1/2	130	95	65	45	2	16	4-Φ14	120	240	265	7.5
20	3/4	150	105	75	55	2	16	4-Φ14	120	245	270	8
25	1	160	115	85	65	2	16	4-Φ14	140	250	275	9
32	1 1/4	180	135	100	78	2	18	4-Φ18	160	260	290	13
40	1 1/2	200	145	110	85	3	18	4-Φ18	180	285	320	15
50	2	230	160	125	100	3	20	4-Φ18	180	300	335	20
65	2 1/2	290	180	145	120	3	22	8-Φ18	240	355	400	28
80	3	310	195	160	135	3	22	8-Φ18	280	400	450	42
100	4	350	230	190	160	3	24	8-Φ23	320	455	495	57
125	5	400	270	220	188	3	28	8-Φ25	320	530	560	71
150	6	480	300	250	218	3	30	8-Φ25	360	610	650	90

*法兰尺寸PN1.0MPa, DN80螺栓孔数量JB78时, Z=4,其它标准时Z=8.
 * Flange Size PN1.0MPa, DN80 bolt hole when the number of JB78, Z=4, when other standards Z=8.

FLUORINE FLANGED GLOBE VALVE

衬氟法兰截止阀

FLANGED FLANGED CHECK VALVES

衬氟法兰止回阀

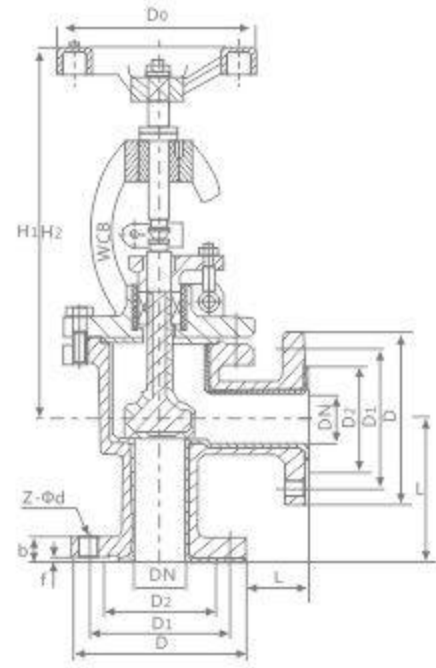

J44^F型法兰连接手动截止阀(角式)
Flange connection manual cut-off valve (angle type)

遵循规范 Follow the standard	STANDARD
设计与制造 Design and manufacture	GB 12233/GB 12235
结构长度 Structure Length	GB 12221(长系列)Long series
法兰尺寸Flange size	GB/T9113.1、GB/T17241.6、JB/T79.1/82.1 (或按合同要求Or by contract requirements)
压力试验Pressure test	GB/T 13927
标志Mark	GB 12220
供货 Availability	GB/T 12252

法兰连接截止阀(角式) Flange connection cut-off valve(angle type)

※设计与制造符合中国国家标准
※Design and manufacture comply with national standards of China
※公称压力PN1.0~2.5MPa
※Nominal pressure PN1.0~2.5MPa
※公称口径DN15~300mm
※Nominal diameter DN15~300mm
※基本结构形式:角式(全衬里)
※Basic structure form: Angle type (entire lining)
※基本型号:手动J44F3 J44F46 电动J944F3 J944F46
※Basic model: Manual J44F3 J44F46 electrically operated J944F3 J944F46
※主要零部件材料:见前一页
※Main parts material: See previous page

主要连接尺寸及重量 Main connection dimension and weight

JB/T79.1-1994
JB/T82.1-1994

公称口径DN		标准值 Standard value							参考值 Reference value			
DN (mm)	NPS (inch)	L	D	D1	D2	F	b	Z-φd	D0	H1	H2	重量 Weight(kg)
PN1.0MPa												
15	1/2	90	95	65	45	2	12	4-φ14	100	240	265	7
20	3/4	95	105	75	55	2	14	4-φ14	100	245	270	7.5
25	1	100	115	85	65	2	14	4-φ14	120	250	275	8
32	1 1/4	105	135	100	78	2	16	4-φ18	120	260	290	12
40	1 1/2	115	145	110	85	3	18	4-φ18	140	290	325	14
50	2	125	160	125	100	3	18	4-φ18	140	300	355	19
65	2 1/2	145	180	145	120	3	20	4-φ18	160	355	400	27
80	3	155	195	160	135	3	20	4-φ18	160	400	450	42
100	4	175	215	180	155	3	22	8-φ18	180	455	495	50
125	5	200	245	210	185	3	24	8-φ18	180	530	560	64
150	6	225	280	240	210	3	24	8-φ23	240	605	650	85
200	8	275	335	295	265	3	24	8-φ23	240	650	770	105
250	10	325	390	350	320	3	26	12-φ23	280	680	800	135
300	12	375	440	400	368	4	28	12-φ23	280	710	835	155
PN1.6MPa												
15	1/2	90	95	65	45	2	14	4-φ14	100	240	265	7
20	3/4	95	105	75	55	2	14	4-φ14	100	245	270	7.5
25	1	100	115	85	65	2	14	4-φ14	120	250	275	8.5
32	1 1/4	105	135	100	78	2	16	4-φ18	140	260	290	12
40	1 1/2	115	145	110	85	3	16	4-φ18	140	290	325	14
50	2	125	160	125	100	3	16	4-φ18	160	300	355	19
65	2 1/2	145	180	145	120	3	18	4-φ18	180	355	400	27
80	3	155	195	160	135	3	20	8-φ18	240	400	450	42
100	4	175	215	180	155	3	20	8-φ18	240	455	495	50
125	5	200	245	210	185	3	22	8-φ18	280	530	560	64
150	6	225	280	240	210	3	24	8-φ23	320	605	650	85
200	8	275	335	295	265	3	26	12-φ23	360	650	770	105
PN2.5MPa												
15	1/2	90	95	65	45	2	16	4-φ14	120	245	270	7.5
20	3/4	95	105	75	55	2	16	4-φ14	120	250	275	8.8
25	1	100	115	85	65	2	16	4-φ14	140	260	290	11
32	1 1/4	105	135	100	78	2	18	4-φ18	140	290	325	13
40	1 1/2	115	145	110	85	3	18	4-φ18	160	300	355	18
50	2	125	160	125	100	3	20	4-φ18	180	355	400	31

*法兰尺寸PN1.0MPa, DN80螺栓孔数量JB78时, Z=4,其它标准时Z=8.

* Flange Size PN1.0MPa, DN80 bolt hole when the number of JB78, Z=4, when other standards Z=8.

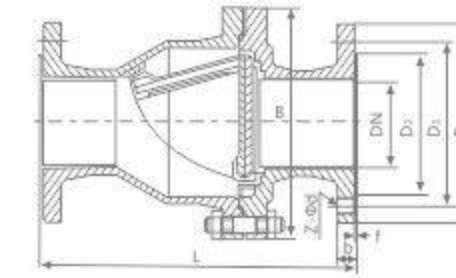

H44^F型止回阀(旋启式)
H44-F₄₆ Check valve (swing type)

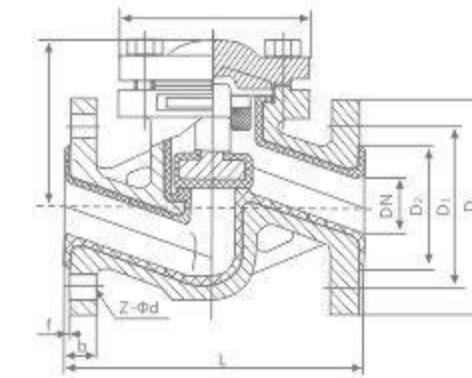

H41^F型法兰连接止回阀(直通升降式)
H41-F₄₆ Flange connection valve (straight-through lift)

遵循规范 Follow the standard	STANDARD
设计与制造 Design and manufacture	GB 12235/GB 2236
结构长度 Structure Length	GB 12221(长短系列)Long - Short Series
法兰尺寸Flange size	JB/T78、JB/T79、JB/T82、JB/F82 (或按合同要求Or by contract requirements)
压力试验Pressure test	GB/T 13927
标志Mark	GB 12220
供货 Availability	GB/T 12252

法兰连接止回阀(全衬里) Flange connection check valve (entire lining)

※设计与制造符合中国国家标准
※Design and manufacture conform to China national standards
※基本结构形式:旋启式、直通升降式
※Basic structure form: Turns on lathe opens the type, to go nonstop to the elevating
※公称压力PN0.6~1.6MPa
※Nominal pressure PN0.6~1.6MPa
※公称口径DN15~500mm
※Nominal size DN15~500mm
※基本型号H41F3 H41F46 H44F3 H44F46
※Basic model H41F3 H41F46 H44F3 H44F46

主要零部件材料表 Main spare part bill of materials

序号 NO.	零件名称 Part name	灰铸铁Grey cast iron	碳钢Carbon Steel	不锈钢Stainless steel		超低碳不锈钢Low carbon stainless steel	
		Z	C	P	R	PL	RL
1	阀体、阀盖、阀瓣 Body, cover, disc	Ht250	WCB	CF8	CF8M	CF3	CF3M
2	衬里层Lining layer	FEP(F46) PFA(可溶性聚四氟乙烯Soluble PTFE) PCTFE(F3) PO(聚烯烃Polyolefin)					
3	销轴Pin	1Cr13/35 WCB 1Cr18Ni9/CF8 00Cr17Ni14Mo2/CF3M					
4	隔膜Diaphragm	35	35	1Cr17Ni2	1Cr17Ni2	0Cr18Ni9	0Cr18Ni9

主要连接尺寸及重量 Main connection dimension and weight

JB/T82.1-1994

公称口径DN		标准值 Standard value							参考值 Reference value		
DN (mm)	NPS (inch)	L	D	D1	D2	f	b	Z-φd	B	H	重量 Weight(kg)
PN0.6MPa											
15	1/2	130	80	55	40	2	12	4-φ12	105	55	4
20	3/4	150	90	65	50	2	14	4-φ12	115	58	5
25	1	160	100	75	60	2	14	4-φ12	128	60	6
32	1 1/4	180	120	90	70	2	16	4-φ14	145	75	7
40	1 1/2	200	130	100	80	3	16	4-φ14	160	82	8
50	2	230	140	110	90	3	16	4-φ14	178	95	10
65	2 1/2	290	160	130	110	3	16	4-φ14	205	105	20
80	3	310	185	150	125	3	18	4-φ18	230	120	25
100	4	350	205	170	145	3	18	4-φ18	255	135	30
125	5	400	235	200	175	3	20	8-φ18	305	158	50
150	6	480	260	225	200	3	20	8-φ18	345	180	65
200	8	495	315	280	255	3	22	8-φ18	415	215	137
250	10	622	370	335	310	3	24	12-φ18	490	240	150
300	12	698	435	395	362	4	24	12-φ23	540	265	185
350	14	787	485	445	412	4	26	12-φ23	585	300	215
400	16	914	535	495	462	4	28	16-φ23	635	360	244
450	18	978	590	550	518	4	28	16-φ23	680	385	276
500	20	978	640	600	568	4	30	16-φ23	740	415	315

FLANGED FLANGED CHECK VALVES

衬氟法兰止回阀

FLANGED DIAPHRAGM VALVE

衬氟法兰隔膜阀

主要连接尺寸及重量 Main connection dimension and weight

JB/T82.1-1994

公称通径DN		标准值Standard value							参考值Reference value		
DN (mm)	NPS (inch)	L	D	D1	D2	f	b	Z-Φd	B	H	重量Weight(kg)
PN1.0MPa											
15	1/2	130	95	65	45	2	12	4-Φ14	105	55	5
20	3/4	150	105	75	55	2	14	4-Φ14	115	58	7
25	1	160	115	85	65	2	14	4-Φ14	128	60	9
32	1 1/4	180	135	100	78	2	16	4-Φ18	145	75	11
40	1 1/2	200	145	110	85	3	18	4-Φ18	160	82	13.5
50	2	230	160	125	100	3	18	4-Φ18	178	95	18
65	2 1/2	290	180	145	120	3	20	4-Φ18	205	105	22
80	3	310	195	160	135	3	20	4-Φ18	230	120	28
100	4	350	215	180	155	3	22	8-Φ18	255	135	34
125	5	400	245	210	185	3	24	8-Φ18	305	158	58
150	6	480	280	240	210	3	24	8-Φ23	345	180	72
200	8	495	335	295	265	3	24	8-Φ23	415	215	150
250	10	622	390	350	320	3	26	12-Φ23	490	240	165
300	12	698	440	400	368	4	28	12-Φ23	540	265	190
350	14	787	500	460	428	4	28	16-Φ23	585	300	225
400	16	914	565	515	482	4	30	16-Φ25	635	360	254
450	18	978	615	565	532	4	30	20-Φ25	680	385	285
500	20	978	670	620	585	4	32	20-Φ25	740	415	333

JB/T79.1-1994

公称通径DN		标准值Standard value							参考值Reference value		
DN (mm)	NPS (inch)	L	D	D1	D2	f	b	Z-Φd	B	H	重量Weight(kg)
PN1.6MPa											
15	1/2	130	95	65	45	2	14	4-Φ14	110	55	6
20	3/4	150	105	75	55	2	16	4-Φ14	120	58	7.8
25	1	160	115	85	65	2	18	4-Φ14	135	60	10
32	1 1/4	180	135	100	78	2	18	4-Φ18	150	75	12.5
40	1 1/2	200	145	110	85	3	20	4-Φ18	165	82	14.5
50	2	230	160	125	100	3	22	4-Φ18	185	95	19.5
65	2 1/2	290	180	145	120	3	24	4-Φ18	210	105	25.5
80	3	310	195	160	135	3	24	8-Φ18	235	120	30
100	4	350	215	180	155	3	26	8-Φ18	260	135	36
125	5	400	245	210	185	3	28	8-Φ18	310	158	62
150	6	480	280	240	210	3	28	8-Φ23	350	180	78
200	8	495	335	295	265	3	30	12-Φ23	420	215	156
250	10	622	405	355	320	3	32	12-Φ25	505	240	172
300	12	698	460	410	375	4	32	12-Φ25	560	265	240
350	14	787	520	470	435	4	34	16-Φ25	605	300	208
400	16	914	580	525	485	4	38	16-Φ30	650	350	265

*法兰尺寸PN1.0MPa, DN80螺栓孔数量JB78时Z=4, 其它标准时Z=8.

*Flange size PN1.0MPa, DN80 bolt hole when the number of JB78 Z = 4, other standards, Z = 8.

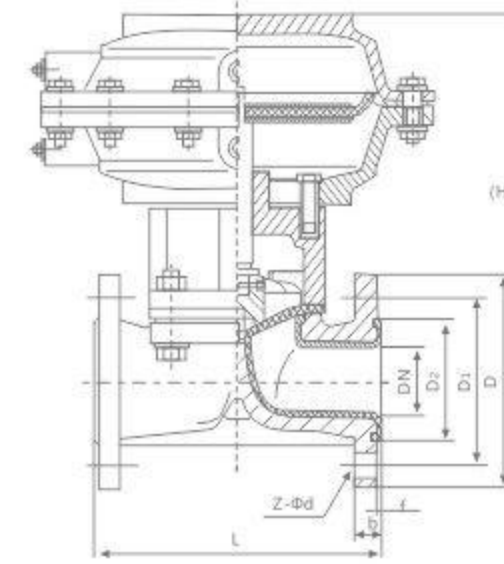

Eg641 F₄₆型气动隔膜阀(堰式)
EG641-F₄₆ Pneumatic diaphragm valve (weir type)

法兰连接隔膜阀 (英标) Flange connection diaphragm valve (British sign)

※设计与制造符合BS英国国家标准 Design and manufacture conform to BS Britain national standards
 ※公称压力PN0.6~1.6MPa Nominal pressure PN0.6~1.6MPa
 ※基本结构形式: 堰式、直流式 Basic structure form: Weir, DC style
 ※公称通径DN20~200mm Nominal size Dn20~200mm

遵循规范 Follow the standard	STANDARD
设计与制造 Design and manufacture	BS5156(一般用途隔膜阀) General Purpose Diaphragm
结构长度 Structure Length	(BS5156值+2f)=saunders
法兰尺寸 Flange size	GB 4216, JB/T82.1 (或按合同要求 Or by contract requirements)
压力试验 Pressure test	API 598
标志 Mark	MSS SP-25
供货 Availability	BS 5156

基本型号 (全衬里) Basic model (entire lining)

手动 Hand	G41F3(堰式Weir)	手动 Hand	G641F3(往复式Reciprocating)
	G41F46(堰式Weir)		G641F46(往复式Reciprocating)
	G45F3(直流式DC type)		G6841F3(常闭式Normally closed)
电动 Electrically	G45F46(直流式DC type)	电动 Electrically	G6841F46(常闭式Normally closed)
	G9841F3(防爆型Explosion-proof)		G941F3(普通型Ordinary)
	G9841F46(防爆型Explosion-proof)		G941F46(普通型Ordinary)

主要零部件材料表 Main spare part bill of materials

序号 NO.	零件名称 Part name	灰铸铁 Grey cast iron	碳钢 Carbon Steel	不锈钢 Stainless steel		超低碳不锈钢 Low carbon stainless steel	
		Z	C	P	R	PL	RL
1	阀体、阀盖、阀瓣 Body, cover, disc	A126C135A	A126 WCB	A315 CF8	A315 CF8M	A315 CF3	A315 CF3M
2	阀杆 Stem	A182 F6a	A182 F6a	A182 F304	A182 F316	A182 F304L	A182 F316L
3	衬里层 Lining layer	FEP(F46) PFA(可溶性聚四氟乙烯 Soluble PTFE) PCTFE(F3) PO(聚烯烃 Polyolefin)					
4	隔膜 Diaphragm	FEP(F46)/CR(氯丁橡胶 Neoprene) PFA(可溶性聚四氟乙烯 Soluble PTFE) /FPDM(乙丙橡胶 EPDM)					
5	螺栓 Bolt	A193 B7	A193 B7	A193 B8	A193 B8M	A193 B8	A193 B8M
6	螺母 Nut	A194 2H	A194 2H	A194 8	A194 8M	A194 8	A194 8M

主要连接尺寸及重量 Main connection dimension and weight

公称通径DN		标准值Standard value							参考值Reference value		
DN (mm)	NPS (inch)	L	D	D1	D2	f	b	Z-Φd	D0	H	重量Weight(kg)
PN1.0MPa											
20	3/4	121	105	75	55	2	14	4-Φ13.5	70	92	3
25	1	131	115	85	65	2	14	4-Φ13.5	83	96	4
32	1 1/4	150	135	100	78	2	16	4-Φ17.5	114	131	6.5
40	1 1/2	163	145	110	85	3	18	4-Φ17.5	114	142	7.5
50	2	194	160	125	100	3	18	4-Φ17.5	140	167	10.5
65	2 1/2	220	180	145	120	3	20	4-Φ17.5	165	203	17.5
80	3	258	195	160	135	3	20	8-Φ17.5	230	216	25
100	4	309	215	180	155	3	22	8-Φ17.5	280	270	36
125	5	362	245	210	185	3	24	8-Φ17.5	280	319	47
150	6	412	280	240	210	3	24	8-Φ22	363	365	73
200	8	529	335	295	265	3	24	8-Φ22	483	462	142
PN1.6MPa											
20	3/4	121	105	75	55	2	16	4-Φ13.5	70	92	3.2
25	1	131	115	85	65	2	18	4-Φ13.5	83	96	4.3
32	1 1/4	150	135	100	78	2	18	4-Φ17.5	114	131	6.9
40	1 1/2	163	145	110	85	3	20	4-Φ17.5	114	142	7.9
50	2	194	160	125	100	3	22	4-Φ17.5	140	167	11

*除非合同另有规定, 隔膜阀在PN0.6MPa时, 其法兰尺寸按PN1.0MPa制造; *法兰尺寸PN1.0MPa, DN80螺栓孔数量JB78时Z=4, 其它标准时Z=8.

*Unless otherwise specified herein, diaphragm valve in PN0.6MPa, its flange sizes manufactured by PN1.0MPa;

*flange size PN1.0MPa, DN80 bolt hole when the number of JB78 Z = 4, other standards, Z = 8.

FLANGED MANUAL BALL VALVE

衬氟法兰手动球阀

FLANGED MANUAL BALL VALVE

衬氟法兰手动球阀

衬氟国标球阀 (Q41F45-16)
Fluorine lined GB ball valve

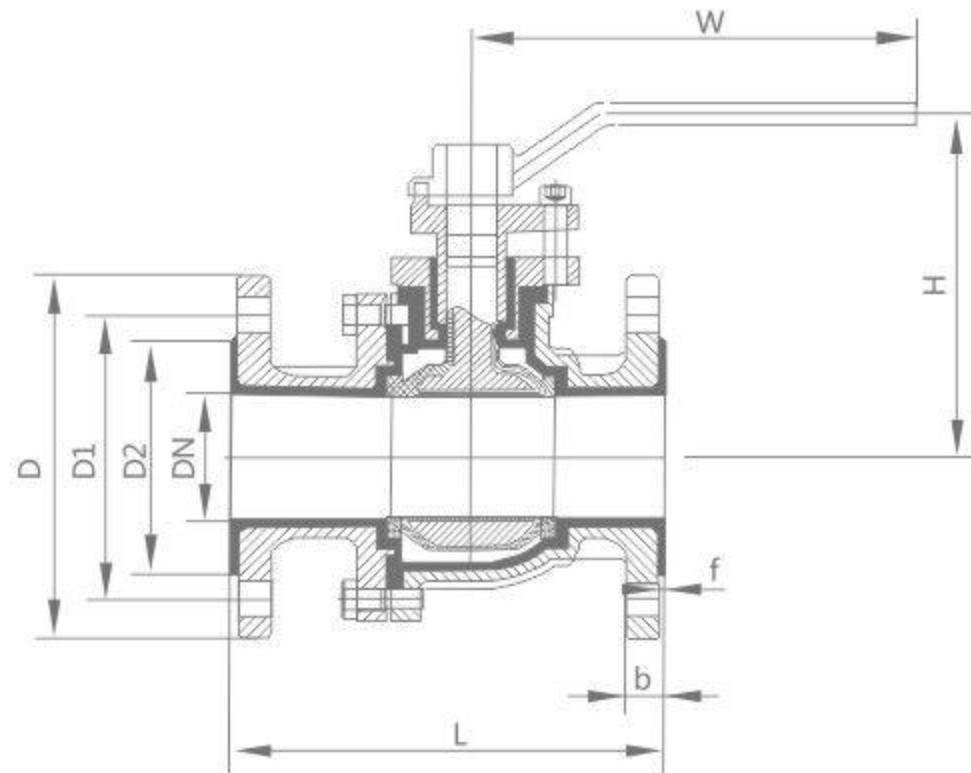

基本型号 Basic model

驱动方式 Drive way	衬里 Lining	型号 Model
手动 Hand	全衬里 Full lining	Q41F4(全衬里)
	全衬里 Full lining	Q41F46(全衬里)
	全衬里 Full lining	Q41FA(全衬里)
蜗轮传动 Worm gear	全衬里 Full lining	Q341F46(全衬里)
	全衬里 Full lining	Q3411F46(全衬里)
	全衬里 Full lining	Q341PFA(全衬里)

技术标准 Technical standards

设计与制造 Design and manufacture	GB/T12237
结构长度 Structure Length	HG/T3704-2003 GB/T12221 ASME B16.10
法兰尺寸 Flange size	HG/T20592-2009 ANSI B16.5a
驱动方式 Drive way	手动, 电动, 气动 Manual, electric, pneumatic
公称压力 Nominal pressure	0.6、1.0、1.6、2.5MPa Class150 JIS10K
压力试验 Pressure test	GB/T13927-92 API 598

主要零部件材料表 Main spare part bill of materials

序号 NO.	零件名称 Part name	碳钢 Carbon Steel		不锈钢 Stainless steel		
		C	P	R	PL	RL
1	阀体、阀盖 Body, cover	WCB	CF8	CF8M	CF3	CF3M
2	球体 Ball	WCB	CF8	CF8M	CF3	CF3M
3	内衬材料阀座	FEP(F46)、PTFE(F4)、PFA(可溶性聚四氟乙烯)、PO(聚烯)、PE(超高分子量聚乙烯)				
4	填料压盖 packing gland	WCB	CF8	CF8M	CF3	CF3M
5	阀座填料	PTFE(F4)聚四氟乙烯				
6	螺栓 Bolt	35	1Cr17Ni12	1Cr17Ni2	1Cr18Ni2	1Cr19Ni2
7	螺母 Nut	45	0Cr19Ni9	0Cr18Ni9	0Cr18Ni9	0Cr18Ni9
8	手柄 Handle	WCB				

主要连接尺寸及重量 Main connection dimensions and weight

JB/T82.1

公称通径 DN		主要尺寸 Main dimensions							参考值 Reference value	
DN (mm)	NPS (inch)	L	D	D1	D2	f	B	Z-Φd	Do	H
PN1.0MPa										
15	1/2	140	95	65	45	3	16	4-14	140	90
20	3/4	140	105	75	55	3	18	4-14	140	100
25	1	150	115	85	65	3	18	4-14	180	105
32	1 1/4	165	140	100	75	3	18	4-18	180	120
40	1 1/2	180	150	110	85	3	18	4-18	225	140
50	2	200	165	125	100	3	18	4-18	225	150
65	2 1/2	220	185	145	120	3	18	4-18	360	160
80	3	250	200	160	135	3	20	8-18	420	215
100	4	280	220	180	155	3	20	8-18	420	240
125	5	320	250	210	185	4	22	8-18	520	250
150	6	360	285	240	210	4	22	8-22	520	290
200	8	400	340	295	265	4	24	8-22	240	340
250	10	450	395	350	320	5	26	12-22	240	380
300	12	610	445	400	370	5	26	12-22	280	450
PN1.6MPa										
15	1/2	140	95	65	45	3	16	4-14	140	90
20	3/4	140	105	75	55	3	18	4-14	140	100
25	1	150	115	85	65	3	18	4-14	180	105
32	1 1/4	165	140	100	75	3	18	4-18	180	120
40	1 1/2	180	150	110	85	3	18	4-18	225	140
50	2	200	165	125	100	3	18	4-18	225	150
65	2 1/2	220	185	145	120	3	18	4-18	360	160
80	3	250	200	160	135	3	20	8-18	420	215
100	4	280	220	180	155	3	20	8-18	420	240
125	5	320	250	210	185	4	22	8-18	520	250
150	6	360	285	240	210	4	22	8-22	520	290
200	8	400	340	295	265	4	24	12-22	240	340
250	10	450	405	355	320	5	26	12-26	240	380
300	12	610	460	410	370	5	28	12-26	280	450

DN200以上Do尺寸为蜗轮手轮尺寸, DN200以下Do尺寸为手柄尺寸
机械标准是 (JB78) 时为4孔
The size of Do above DN200 is worm wheel handwheel size, and the size of Do below DN200 is handle size
The mechanical standard is (JB78) for 4 holes

FLUORINE LINED CLAMP BUTTERFLY VALVE (MIDDLE LINE)

衬氟对夹蝶阀(中线)

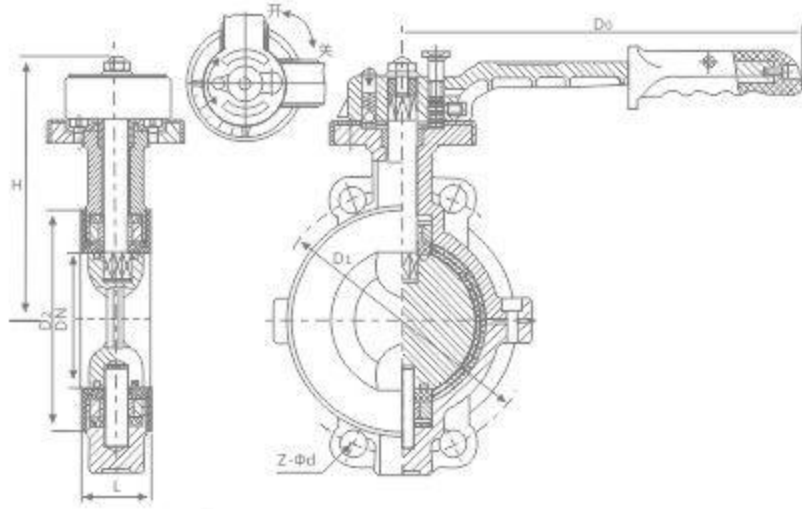

DA71^{F4}_{F/P} 型对夹式手动蝶阀 (中线)
DA71^{F4}_{F/P} Wafer type manual butterfly valve type (middle)

遵循规范 Follow the standard	STANDARD
设计与制造 Design and manufacture	GB 12238(中线Midline)
结构长度 Structure Length	GB 12221(短系列Short Series)
法兰尺寸 Flange size	JB79/JB82 (或按合同要求Or by contract requirements)
压力试验 Pressure test	GB/T 13927
标志 Mark	GB 12220
供货 Availability	GB/T 12252

对夹连接蝶阀 (中线) Wafer butterfly valves (middle)

※设计与制造符合中国国家标准

※基本结构形式 (蝶板轴与阀体/阀座中心重合)

a. DA71F46全衬里型

阀体全衬里/蝶板全衬里/蝶板与蝶板轴合为一体

b. DA71F4全衬里型

阀体全衬里/蝶板全衬里/蝶板与蝶板轴组合装配

c. DA71F/P半衬里型

阀体全衬里/蝶板为不锈钢(不衬)/蝶板与蝶板轴组合装配

Design and manufacture comply with national standards of China
Basic structure of the form (the disc axis and the valve / seat centers coincide)

a. DA71F46 full lining type

The whole body lining / disc full lining / disc and disc axis into one

b. DA71F4 full lining type

The whole body lining / disc full lining / disc and disc shaft and assembled

c. DA71F / P-type semi-lining

The whole body lining / disc of stainless steel (not lined) / disc and disc shaft and assembled

基本型号 Basic model

公称压力PN0.6~1.6MPa 公称口径DN40~1200mm

Nominal pressure PN0.6~1.6MPa Nominal diameter DN40~1200mm

手动 Hand	DA71F/P(半衬Half lining)	蜗轮传动 Worm drive	DA371F/P(半衬Half lining)
	DA71F3 (全衬里Full lining)		DA371F3 (全衬里Full lining)
	DA71F4 (全衬里Full lining)		DA371F4 (全衬里Full lining)
	DA71F46 (全衬里Full lining)		DA371F46 (全衬里Full lining)
气动 Pneumatic	DA671F/P(半衬Half lining)	电动 Electrically	DA971F/P(半衬Half lining)
	DA671F3 (全衬里Full lining)		DA971F3 (全衬里Full lining)
	DA671F4 (全衬里Full lining)		DA971F4 (全衬里Full lining)
	DA671F46 (全衬里Full lining)		DA971F46 (全衬里Full lining)

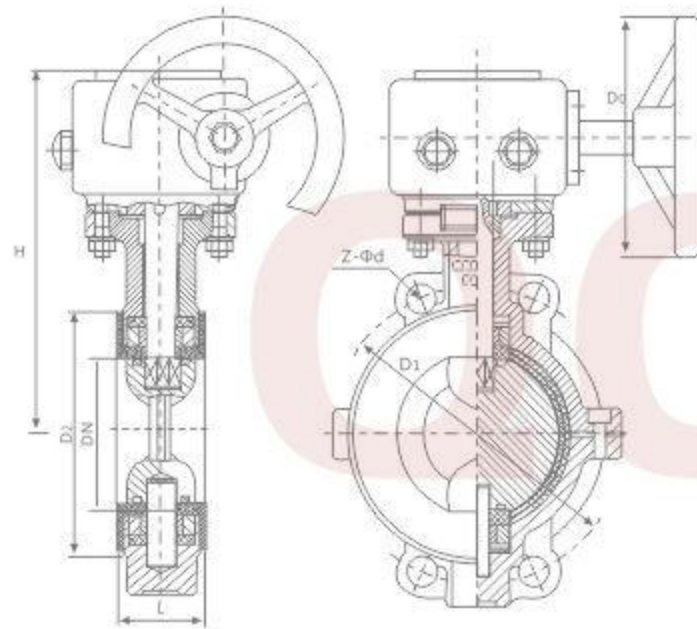

DA371^{F4}_{F/P} 型对夹式蜗轮传动蝶阀 (中线)

DA371^{F4}_{F/P} Wafer type butterfly valve worm gear transmission (middle)

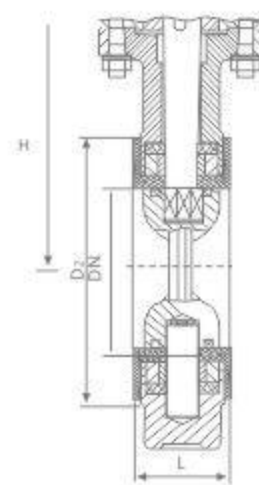

DA371F46型对夹式蜗轮传动蝶阀 (中线)
DA371F46 Worm drive type wafer type butterfly valve (middle)

FLUORINE LINED CLAMP BUTTERFLY VALVE (MIDDLE LINE)

衬氟对夹蝶阀(中线)

主要零部件材料表 Main spare part bill of materials

序号 NO.	零件名称 Part Name	灰铸铁	碳钢	不锈钢Stainless steel		超低碳不锈钢Low carbon stainless steel	
		Z	C	P	R	PL	RL
1	上、下阀体 Upper and lower body	HT250	WCB	CF8	CF8M	CF3	CF3M
2	蝶板Disc	WCB	35 (锻)	CF8	CF8M	CF3	CF3M
3	蝶板轴 Butterfly Plates	1Cr13	2Cr13	0Cr18Ni9	0Cr18Ni12Mo2	00Cr18Ni10	00Cr18Ni14Mo2
4	衬里层/阀座 Lining layer / seat	PTFE(F4) PCTFE(F3) FEP(F46) PFA(可溶F4) PO (聚烯烃Polyolefin)					
5	O型圈O-ring	FPM(氟橡胶Viton)					
6	弹簧条(垫) Spring section (pad)	Si(硅橡胶Silicone rubber)					
7	调节定位座 Adjustment in Block	0Cr18Ni9	0Cr18Ni9	1Cr18Ni9Ti	1Cr18Ni12Mo2Ti	00Cr18Ni10	00Cr18Ni14Mo2
8	螺栓Bolt	35	35	1Cr17Ni2	1Cr17Ni2	0Cr18Ni9	0Cr18Ni12Mo2
9	螺母Nut	25	25	0Cr18Ni9	0Cr18Ni9	0Cr18Ni9	0Cr18Ni12Mo2
10	手柄Handle	ZL 101(铸造铝合金Cast Aluminum)					

主要连接尺寸及重量 Main connection dimension and weight

JB/T82.1

公称口径DN		标准值Standard value							参考值Reference value		
DN (mm)	NPS (inch)	L	D	D1	D2	f	B	Z-φd	D0	H	重量Weight(kg)
PN0.6MPa											
40	1 1/2	33	130	100	80	3	12	4-φ14	160	140	2.5
50	2	43	140	110	90	3	12	4-φ14	200	145	3.5
65	2 1/2	46	160	130	110	3	14	4-φ14	250	155	4.5
80	3	46	185	150	125	3	14	4-φ18	250	165	6
100	4	52	205	170	145	3	14	4-φ18	250	180	7.5
125	5	56	235	200	175	3	14	8-φ18	300	203	11
150	6	56	260	225	200	3	16	8-φ18	300	225	16
200	8	60	315	280	255	3	18	8-φ18	200*	275	48
250	10	68	370	335	310	3	22	12-φ18	200*	315	60
300	12	78	435	395	362	4	22	12-φ23	240*	348	75
350	14	78	485	445	412	4	22	12-φ23	240*	415	82
400	16	102	535	495	462	4	22	16-φ23	280*	460	123
450	18	114	590	550	518	4	24	16-φ23	280*	500	150
500	20	127	640	600	568	4	24	16-φ23	320*	530	180
600	24	154	755	705	670	5	24	20-φ25	320*	610	225
700	28	165	860	810	775	5	26	24-φ25	360*	675	315
800	32	190	975	920	880	5	26	24-φ30	360*	805	385
900	36	203	1075	1020	980	5	28	24-φ30	380*	995	420
1000	40	216	1175	1120	1080	5	30	28-φ30	400*	1170	620
1200	48	254	1375	1320	1280	5	30	32-φ30	400*	1295	788

*法兰尺寸D、D1、D2、Z-φd、f、b数值是与蝶阀连接的标准法兰尺寸，简图中尺寸代号仅是其中一部分。
Flange size D, D1, D2, Z-φd, f, b values are connected with a standard butterfly valve flange size, sketch in the size of code is only part of it.

FLUORINE LINED CLAMP BUTTERFLY VALVE (MIDDLE LINE)

衬氟对夹蝶阀(中线)

FLANGED FLANGED BUTTERFLY VALVE (MIDDLE LINE)

衬氟法兰蝶阀(中线)

主要连接尺寸及重量 Main connection dimensions and weight

JB/T82.1

公称通径DN		标准值Standard value							参考值Reference value		
DN (mm)	NPS (inch)	L	D	D1	D2	f	B	Z-Φd	D0	H	重量(kg)
PN1.0MPa											
40	1 1/2	33	145	110	85	3	18	4-Φ18	160	140	3
50	2	43	160	125	100	3	18	4-Φ18	200	145	4
65	2 1/2	46	180	145	120	3	20	4-Φ18	250	155	6
80	3	46	195	160	135	3	20	8-Φ18	250	165	8
100	4	52	215	180	155	3	22	8-Φ18	250	180	12
125	5	56	245	210	185	3	24	8-Φ18	300	203	18
150	6	56	280	240	210	3	24	8-Φ23	300	225	28
200	8	60	335	295	265	3	24	8-Φ23	200*	275	56
250	10	68	390	350	320	3	26	12-Φ23	200*	315	72
300	12	78	440	400	368	4	28	12-Φ23	240*	348	88
350	14	78	500	460	428	4	28	16-Φ23	240*	415	120
400	16	102	565	515	482	4	30	16-Φ25	280*	460	145
450	18	114	615	565	532	4	30	20-Φ25	280*	500	165
500	20	127	670	620	585	4	32	20-Φ25	320*	530	195
600	24	154	780	725	685	5	36	20-Φ30	320*	610	268
700	28	165	895	840	800	5	40	24-Φ30	360*	675	320
800	32	190	1010	950	905	5	44	24-Φ34	360*	805	395
900	36	203	1110	1050	1005	5	46	28-Φ34	380*	995	450
1000	40	216	1220	1160	1115	5	50	28-Φ34	400*	1170	680
1200	48	254	1450	1380	1325	5	56	32-Φ41	400*	1295	825
PN1.6MPa											
JB/T79.1											
40	1 1/2	33	145	110	85	3	20	4-Φ18	200	145	4
50	2	43	160	125	100	3	22	4-Φ18	250	150	5
65	2 1/2	46	180	145	120	3	24	4-Φ18	250	160	7
80	3	46	195	160	135	3	24	8-Φ18	250	170	10
100	4	52	215	180	155	3	26	8-Φ18	300	185	14
125	5	56	245	210	185	3	28	8-Φ18	300	210	22
150	6	56	280	240	210	3	28	8-Φ23	200*	230	32
200	8	60	335	295	265	3	30	12-Φ23	200*	285	66
250	10	68	405	355	320	3	32	12-Φ25	240*	325	80
300	12	78	460	410	375	4	32	12-Φ25	240*	360	94
350	14	78	520	470	435	4	34	16-Φ25	280*	430	125
400	16	102	580	525	485	4	38	16-Φ30	280*	475	150
450	18	114	640	585	545	4	42	20-Φ30	320*	525	172
500	20	127	705	650	608	4	48	20-Φ34	320*	565	225
600	24	154	840	770	718	5	50	20-Φ41	360*	620	290
700	28	165	910	840	788	5	54	24-Φ41	360*	686	330
800	32	190	1020	950	898	5	54	24-Φ41	380*	815	425
900	36	203	1120	1050	998	5	54	28-Φ41	400*	1010	495
1000	40	216	1255	1170	1110	5	60	28-Φ48	400*	1185	710

*法兰尺寸D、D1、D2、Z-Φd、f、b数值是与蝶阀连接的标准法兰尺寸，简图中尺寸代号仅是其中一部分。

*法兰尺寸PN1.0MPa、DN80螺孔数量JB78时Z=4,其它标准时Z=8。

* Flange Size D, D1, D2, Z-Φd, f, b values are connected with the standard flange butterfly valve size, sketch in the size of code is only part of it.

* Flange Size PN1.0MPa, DN80 screw when the number of JB78 Z = 4, other standards, Z = 8.

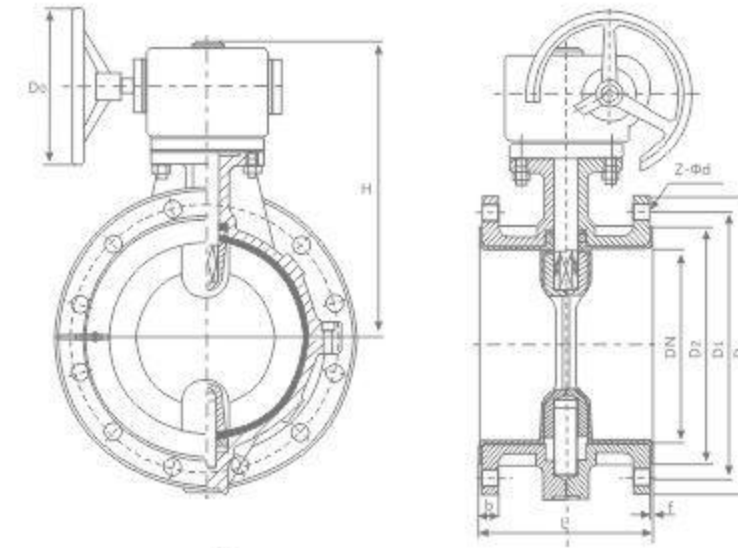

D₃₄₁ F₁/P 型法兰连接蜗轮传动蝶阀(中线)
D₃₄₁ F₁/P Worm drive flanged butterfly valve (middle)

法兰连接蝶阀(中线) Flanged butterfly valve (middle)

※设计与制造符合中国国家标准

※基本结构形式(蝶板轴与阀体/阀座中心重合)

a. DA71F46全衬里型 阀体全衬里/蝶板全衬里/蝶板与蝶板轴为一体

b. DA71F4全衬里型 阀体全衬里/蝶板全衬里/蝶板与蝶板轴组合装配

c. DA71F/P半衬里型 阀体全衬里/蝶板为不锈钢(不衬)/蝶板与蝶板轴组合装配

※Design and manufacture comply with national standards of China

※basic structure of the form (the disc axis and the valve / seat centers coincide)

a. DA71F46 full lining type Full body lining / disc full lining / disc with the disc axis into one

b. DA71F4 full lining type The whole body lining / disc full lining / disc and disc shaft and assembled

c. DA71F / P-type semi-lining The whole body lining / disc of stainless steel (not lined) / disc and disc shaft and assembled

遵循规范 Follow the standard	STANDARD
设计与制造 Design and manufacture	GB 12238(中线Midline)
结构长度 Structure Length	GB 12221(短系列Short Series)
法兰尺寸 Flange size	JB79/JB82 (或按合同要求Or by contract requirements)
压力试验 Pressure test	GB/T 13927
标志 Mark	GB 12220
供货 Availability	GB/T 12252

基本型号 Basic model

公称压力PN0.6~1.6MPa 公称通径DN40~1200mm

Nominal pressure PN0.6~1.6MPa Nominal diameter DN40~1200mm

操作方式 Operation	传动方式 Drive	衬里材料 Lining	型号 Model
手动 Hand	蜗轮传动 Worm drive	DA71F/P(半衬 Half lining)	DA371F/P(半衬 Half lining)
		DA71F3(全衬里 Full lining)	DA371F3(全衬里 Full lining)
		DA71F46(全衬里 Full lining)	DA371F46(全衬里 Full lining)
气动 Pneumatic	电动 Electrically	DA671F/P(半衬 Half lining)	DA971F/P(半衬 Half lining)
		DA671F3(全衬里 Full lining)	DA971F3(全衬里 Full lining)
		DA671F46(全衬里 Full lining)	DA971F46(全衬里 Full lining)

主要零部件材料表 Material form the main components

序号 NO.	零件名称 Part Name	灰铸铁 Grey cast iron	碳钢 Carbon steel	不锈钢 Stainless steel		超低碳不锈钢 Low carbon stainless steel	
		Z	C	P	R	PL	RL
1	上、下阀体 Upper and lower body	HT250	WCB	CF8	CF8M	CF3	CF3M
2	蝶板轴 Butterfly Plates	1Cr13	2Cr13	1Cr18Ni9Ti	1Cr18Ni12Mo2Ti	00Cr18Ni10	00Cr18Ni14Mo2
3	衬里层/阀座 Lining layer / seat	PTFE(F4) PCTFE(F3) FEP(F46) PFA(可溶F4) Po (聚烯烃 Polyolefin)					
4	蝶板/填料压盖 Disc / packing gland	WCB	WCB	CF8	CF8M	CF3	CF3M
5	支架 Support	WCB (碳钢 Carbon steel)			CF8(不锈钢 Stainless steel)		
6	填料 Filler	PTFE(F4)					
7	螺栓 Bolt	35	35	1Cr17Ni2	1Cr17Ni2	0Cr18Ni9	0Cr18Ni12Mo2
8	螺母 Nut	25	25	0Cr18Ni9	0Cr18Ni9	0Cr18Ni9	0Cr18Ni12Mo2